



Manufactured by:
 Backyard Discovery
 3305 Airport Drive, Pittsburg, KS
 66762 800-856-4445

Basepoint Business Centre: Rivermead Drive, Westlea, Swindon SN5 7EX Phone: 0800-118-2476
 J.P. Coenstraat 7, The Bridge, The Hague, 2595 WP, Netherlands Phone: 08005678990

14x12 NORWOOD GAZEBO

MODEL # : 2206021



Please visit www.backyarddiscovery.com
 For the most up to date assembly manual, to register your product, or to order replacement parts *Para obtener instrucciones en español, visite* www.backyarddiscovery.com



EASY STEP-BY-STEP
 3D INTERACTIVE INSTRUCTIONS
 DOWNLOAD THE FREE APP



INSTALLATION
 SERVICES
 AVAILABLE!*

See inside for details

OWNER'S MANUAL - BASIC SETUP DIMENSIONS & ASSEMBLY NOTES

It is critically important that you start with square and level footings, concrete pad or deck to attach your structure

- Pay close attention to the items needed for each step. Make sure you are using the correct hardware for each step. Using incorrect hardware may result in improper assembly
- Remember to double check for underground utilities and overhead electrical lines

Post mounts are provided with your structure which allows you to permanently install your structure to a pre-existing or new wood or concrete surface. See Anchor Instructions for further details and recommendations.

- The hardware to attach the post mounts to the structure is included.
- The hardware to mount the structure permanently to a concrete surface is included.
- The hardware to mount the structure permanently to a wood deck is NOT included and will need to be purchased separately. You must ensure there is ample structural support under the deck before permanently attaching.

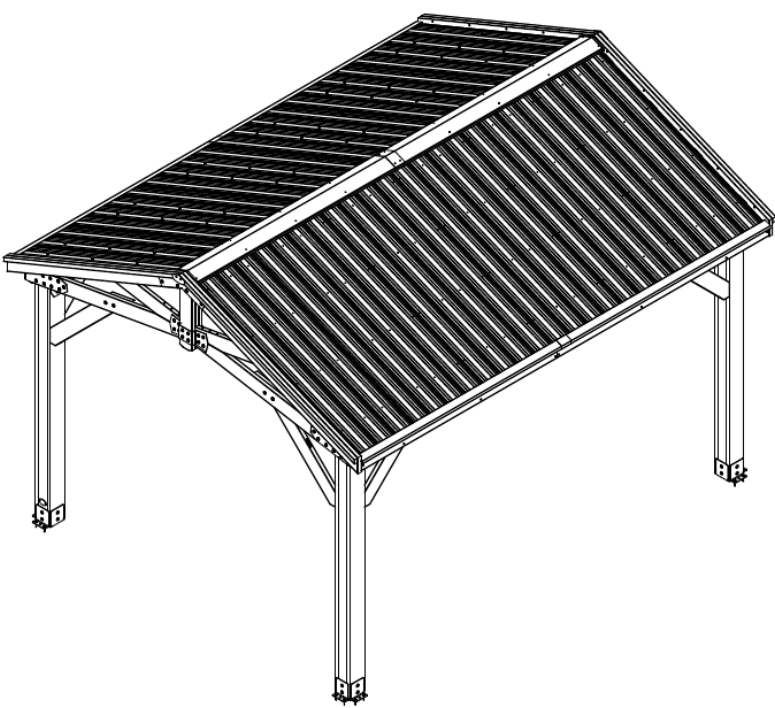
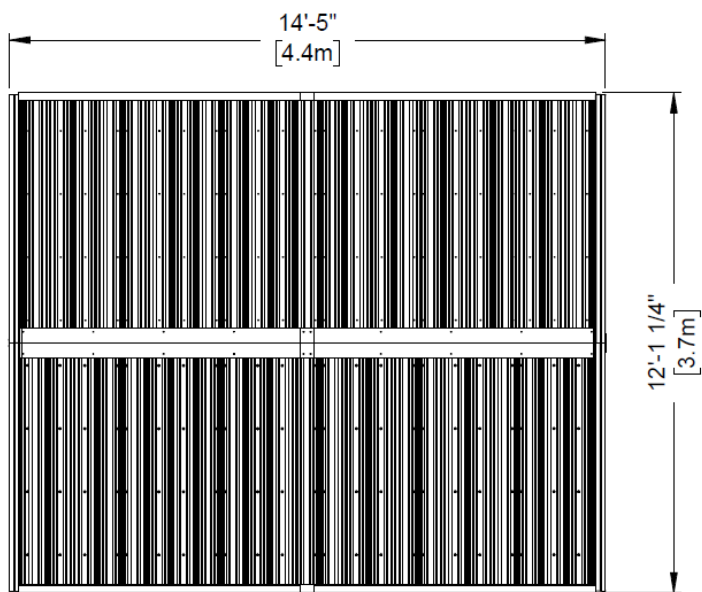
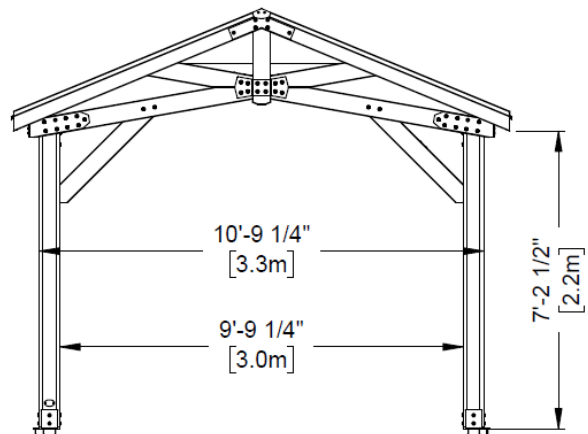
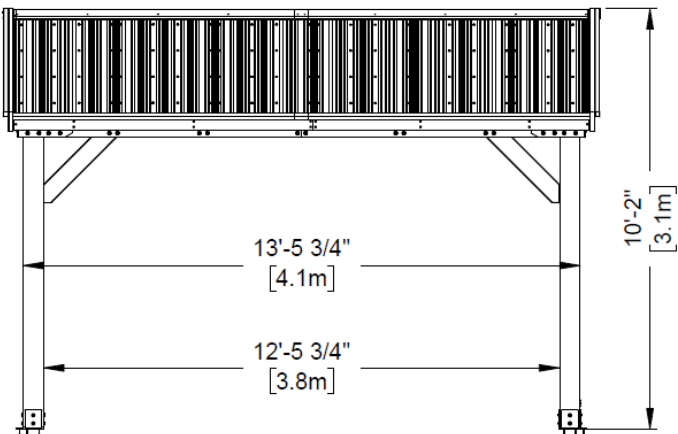

OWNER'S MANUAL - ANCHORING LAYOUT

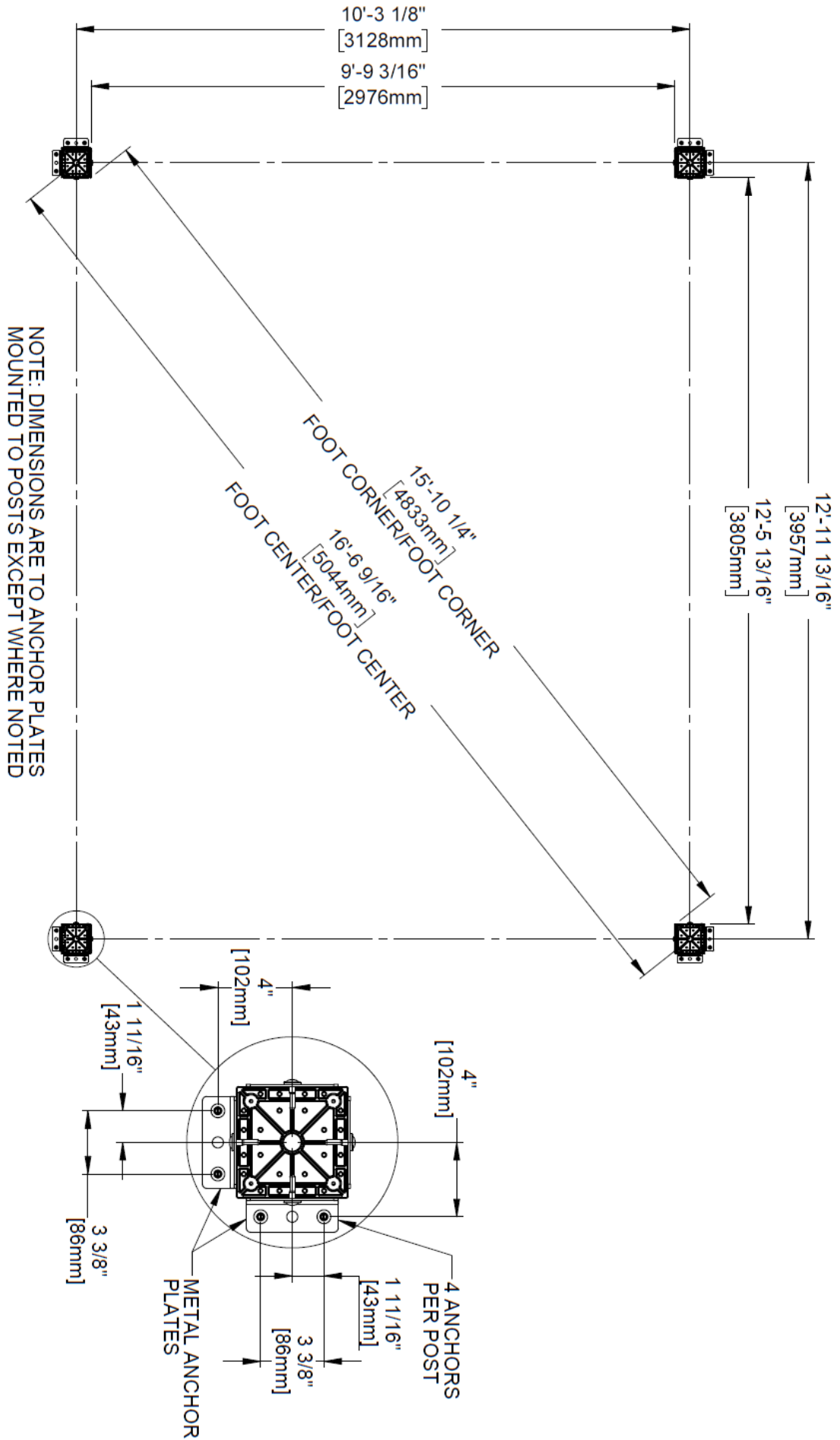

OWNER'S MANUAL - PARTS IDENTIFICATION

Wood Components (Not to Scale)



D01 | GABLE BOARD - W4L16850
(x4) | 1 3/8"x5 1/4"x24 1/4" (36x134x615)

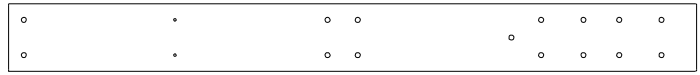

D02 | TOP RAIL - W4L16886
(x4) | 1 3/8"x5 1/4"x53 3/4" (36x134x1366)



D03 | TOP RAIL - W4L16887
(x2) | 1 3/8"x5 1/4"x57" (36x134x1448)



D04 | CORBEL - W4L16853
(x4) | 1 3/8"x5 1/4"x35 7/8" (36x134x910)



D05 | GABLE BOARD - W4L16854
(x2) | 1 3/8"x1 1/2"x5 1/4" (36x38x134)



D06 | CORBEL - W4L16855
(x3) | 1 3/8"x5 1/4"x45 5/8" (36x134x1160)



D07 | TOP RAIL - W4L16888
(x4) | 1 3/8"x5 1/4"x82 1/4" (36x134x2091)



E01 | RAFTER - W4L16858
(x8) | 1 3/8"x3 3/8"x76 3/8" (36x86x1941)



E02 | TRUSS - W4L16859
(x4) | 1 7/16"x1 15/16"x74 15/16" (36x50x1903)



E03 | SHEATHING BOARD - W4L16889
(x8) | 1 3/8"x3 3/8"x80 3/8" (36x86x2040)



E04 | SHEATHING BOARD - W4L16890
(x8) | 1 3/8"x3 3/8"x87" (36x86x2209)



E05 | RAFTER - W4L16862
(x4) | 1 3/8"x3 3/8"x76 3/8" (36x86x1941)



E06 | ACCESSORY TRUSS - W4L16863
(x2) | 1 3/8"x3 3/8"x73 13/16" (36x86x1875)



H02 | FASCIA - W4L16891
(x2) | 1"x3 3/8"x80 3/8" (24x86x2040)



H03 | FASCIA - W4L16892
(x2) | 1"x3 3/8"x87" (24x86x2209)



H04 | RAFTER - W4L16893
(x2) | 1"x3 3/8"x89 1/4" (24x86x2267)

OWNER'S MANUAL - PARTS IDENTIFICATION

Wood Components (Not to Scale)



H05 | RAFTER - W4L16894
(x2) | 1"x3 3/8"x63 1/2" (24x86x1766)

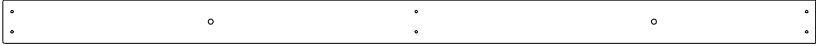

H06 | FASCIA - W4L16895
(x2) | 1"x3 3/8"x63 1/2" (24x86x1614)



H07 | FASCIA - W4L16896
(x2) | 1"x3 3/8"x70 1/8" (24x86x1783)



H08 | NOTCHED SUPPORT BOARD - W4L16915
(x2) | 1"x3 3/8"x89 1/2" (24x86x2274)

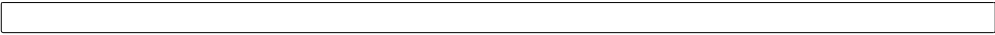

J09 | RIDGE CAP STIFFENER - W4L16897
(x2) | 1"x2 3/8"x77 5/8" (24x60x1973)



J10 | RIDGE CAP STIFFENER - W4L16898
(x2) | 1"x2 3/8"x89 1/2" (24x60x2273)



CA01 | CORBEL - W2A03504
(x1) | 1 7/16"x5 3/8"x46 1/16" (36x136x1160)



GP1 | GABLE PANEL - W2A03499
(x2) | 2 13/16"x5 1/4"x80 3/16" (72x134x2037)



GP2 | GABLE PANEL - W2A03500
(x2) | 2 13/16"x5 1/4"x80 3/16" (72x134x2037)



P01 | POST - W2A03501
(x2) | 6"x6"x89 1/2" (152x152x2274)



P02 | POST - W2A03502
(x2) | 6"x6"x89 1/2" (152x152x2274)

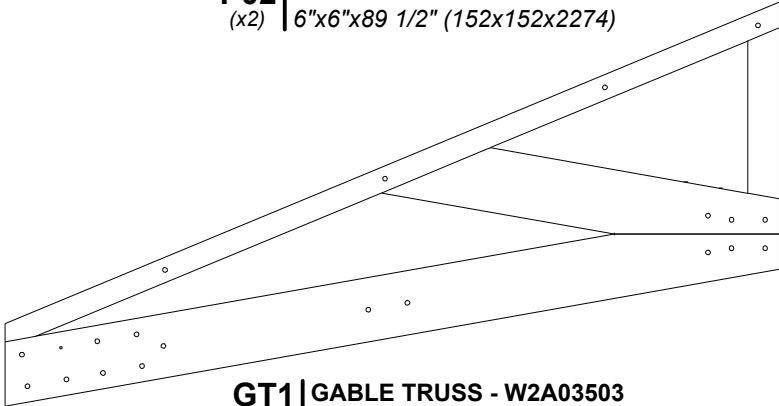

GT1 | GABLE TRUSS - W2A03503
(x4) | 1 7/16"x33 5/8"x64 9/16" (36x854x1640)

OWNER'S MANUAL - PARTS IDENTIFICATION

Hardware Components

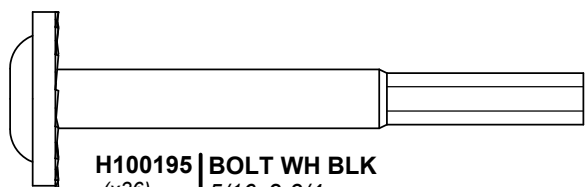

H100195 | BOLT WH BLK
(x36) | 5/16x2-3/4

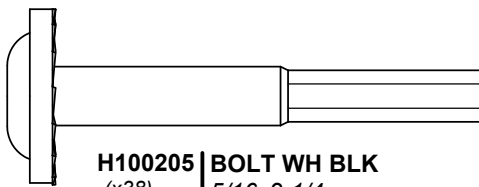

H100205 | BOLT WH BLK
(x38) | 5/16x2-1/4

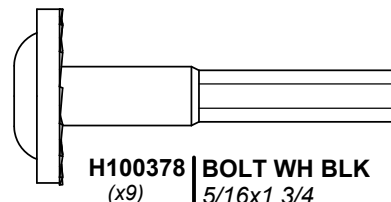

H100378 | BOLT WH BLK
(x9) | 5/16x1 3/4

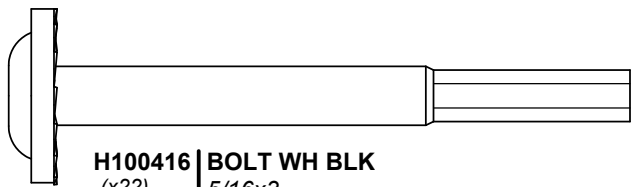

H100416 | BOLT WH BLK
(x22) | 5/16x3

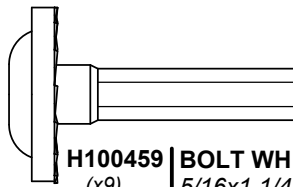

H100459 | BOLT WH BLK
(x9) | 5/16x1 1/4

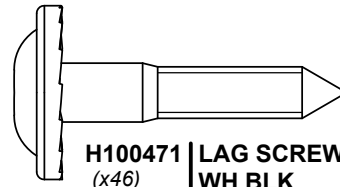

H100471 | LAG SCREW
(x46) | WH BLK
5/16x1 1/2

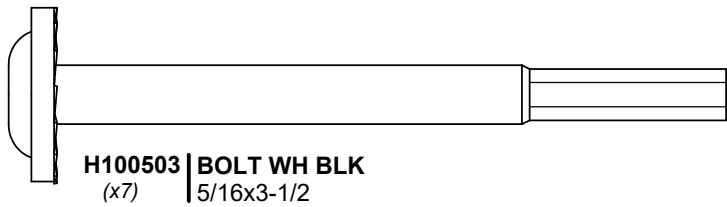

H100503 | BOLT WH BLK
(x7) | 5/16x3-1/2

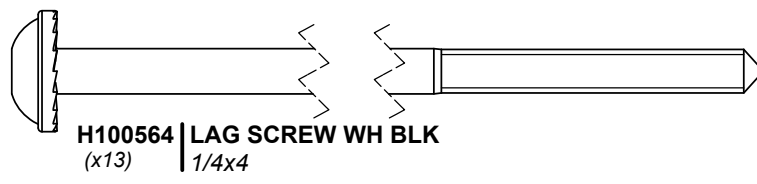

H100564 | LAG SCREW WH BLK
(x13) | 1/4x4

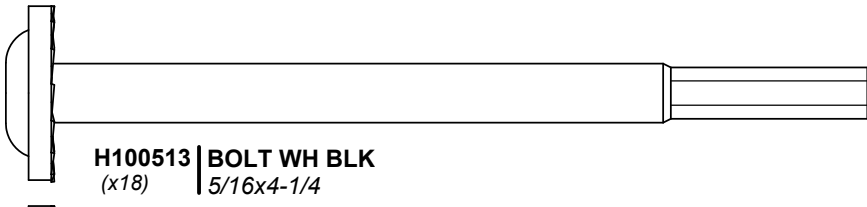

H100513 | BOLT WH BLK
(x18) | 5/16x4-1/4

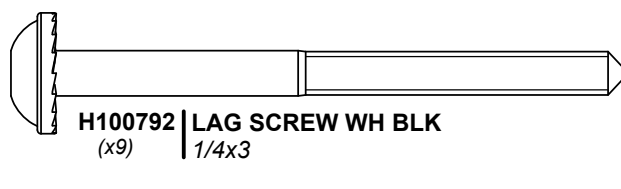

H100792 | LAG SCREW WH BLK
(x9) | 1/4x3

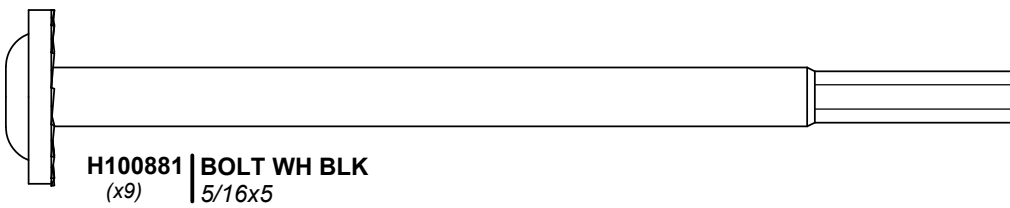

H100881 | BOLT WH BLK
(x9) | 5/16x5

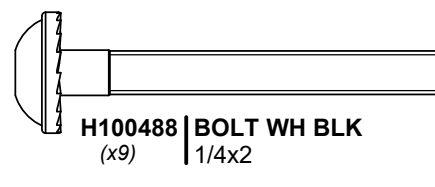

H100488 | BOLT WH BLK
(x9) | 1/4x2

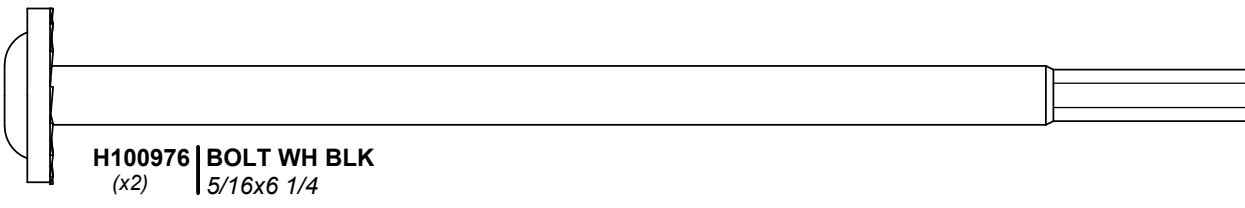

H100976 | BOLT WH BLK
(x2) | 5/16x6 1/4

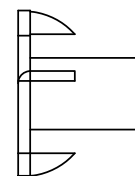

H100379 | T-NUT BLK
(x98) | 5/16

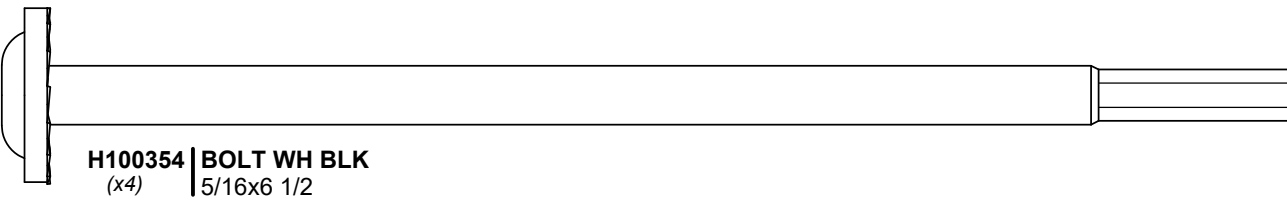

H100354 | BOLT WH BLK
(x4) | 5/16x6 1/2



H101046 | BOLT WH BLK
(x13) | 5/16x7 1/2

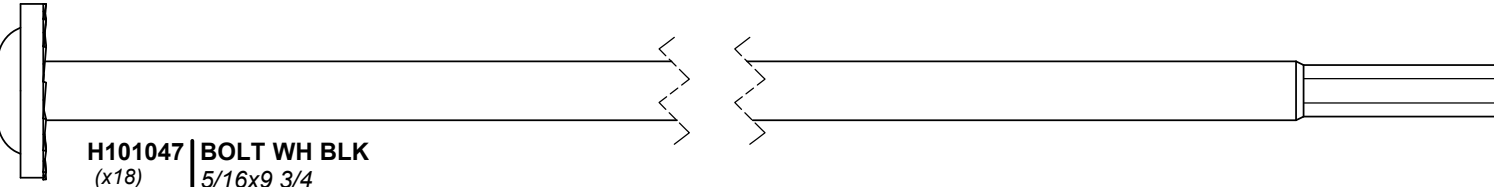

H101047 | BOLT WH BLK
(x18) | 5/16x9 3/4

OWNER'S MANUAL - PARTS IDENTIFICATION

Hardware Components

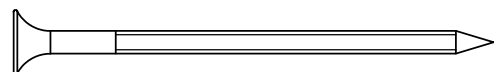

H100201 | SCREW PFH BLK
(x39) | 8x2-1/2



H100483 | SCREW PFH BLK
(x4) | 8x2 1/4

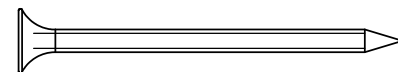

H100391 | SCREW PFH BLK
(x120) | 8x2

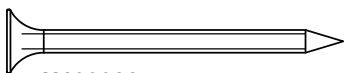

H100382 | SCREW PFH BLK
(x11) | 8x1 3/4

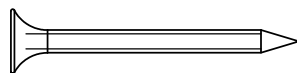

H100200 | SCREW PFH BLK
(x24) | 8x1 1/2

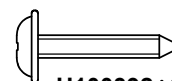

H100392 | SCREW PWH BLK
(x24) | 8x3/4

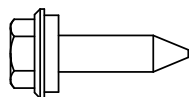

**H100833 | SCREW
WOODGRIP**
(x208) | 10x3/4

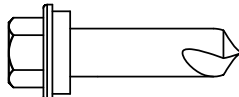

**H100759 | SCREW
TAPPING**
(x22) | 1/4x1

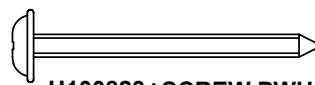

H100823 | SCREW PWH BLK
(x17) | 8x1-1/2

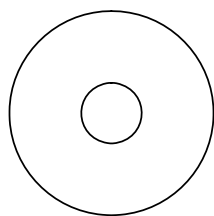

**H100478 | WASHER FLAT
BLK**
(x82) | 8x27

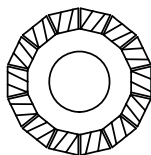

**H100198 | WASHER LOCK
EXT BLK 8x19**
(x76)

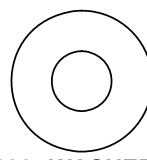

**H100630 | WASHER FLAT
BLK**
(x26) | 8x19

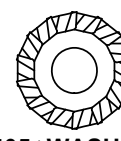

**H100405 | WASHER LOCK
EXT BLK 6x15**
(x22)

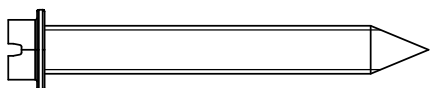

H100120 | SCREW CONCRETE ANCHOR
(x18) | 1/4x2

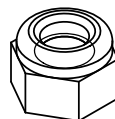

H100479 | NUT LOCK BLK
(x76) | 5/16



H100653 | NUT LOCK BLK
(x9) | 1/4

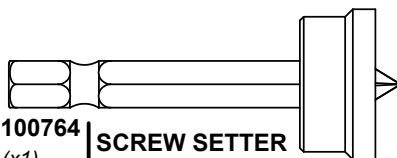

H100764 | SCREW SETTER
(x1)

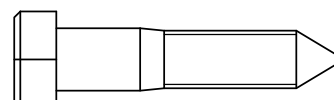

H100659 | LAG SCREW BLK
(x4) | 5/16x1 1/2

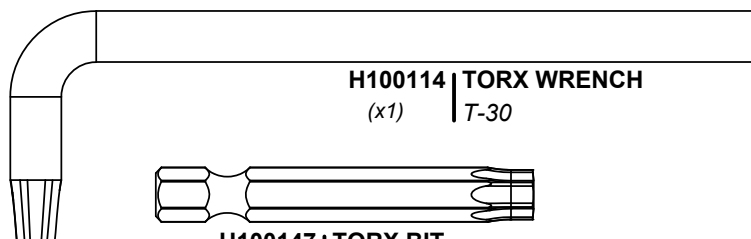

H100114 | TORX WRENCH
(x1) | T-30

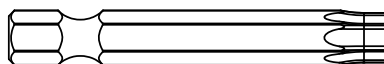

H100147 | TORX BIT
(x1) | T-30

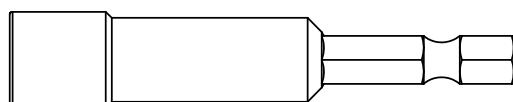

H101106 | HEX DRIVER
(x1) | 5/16



H101100 | MAGNETIC DRIVER
(x1)

OWNER'S MANUAL - PARTS IDENTIFICATION

Accessory Components (Not to Scale)

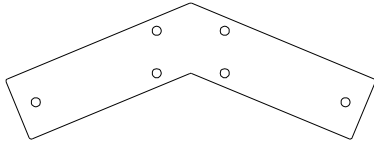

A4M01130 | GABLE BRACKET
(x2)

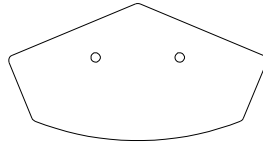

A4M01147 | PEAK SEAM BRACKET
(x2)

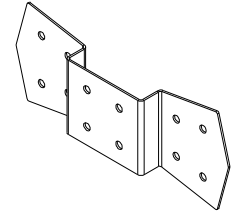

A4M01129 | GABLE BRACKET
(x4)

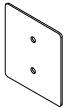

A4M00978 | POST PLATE
(x8)

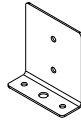

A4M00977 | POST ANCHORING PLATE
(x8)

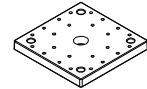

A6P00308 | 6x6 POST FOOT
(x4)

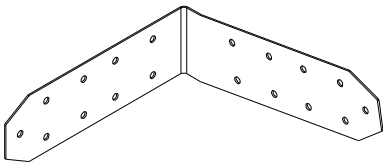

A4M01301 | RIGHT OUTSIDE BRACKET
(x2)

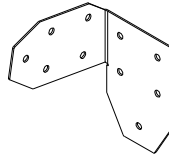

A4M01232 | LEFT ANGLE BRACKET
(x2)

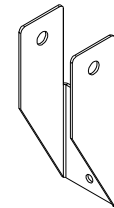

A4M01228 | RAFTER BRACKET
(x8)

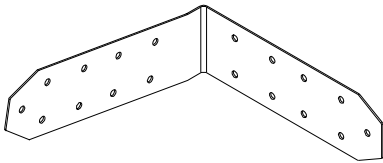

A4M01302 | LEFT OUTSIDE BRACKET
(x2)

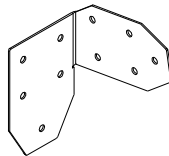

A4M01233 | RIGHT ANGLE BRACKET
(x2)

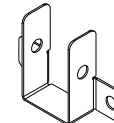

A4M01148 | TRUSS BRACKET
(x2)



A100241 | BYD ID TAG
(x1) | (SMALL)
WITHOUT AGES

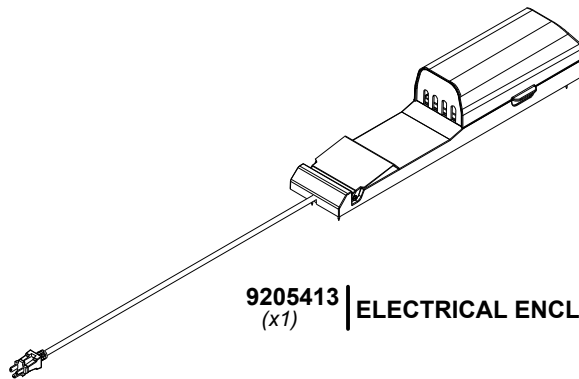

9205413 | ELECTRICAL ENCLOSURE
(x1)

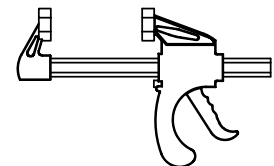

A6P00460 | 6" QUICK RELEASE
(x2) | BAR CLAMP

OWNER'S MANUAL - PARTS IDENTIFICATION

Accessory Components (Not to Scale)

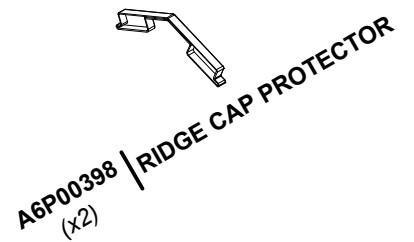
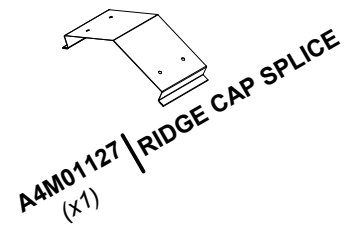
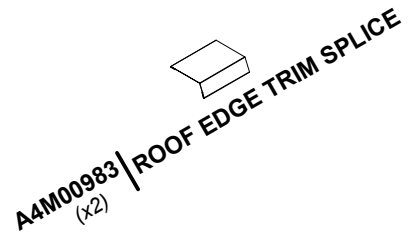
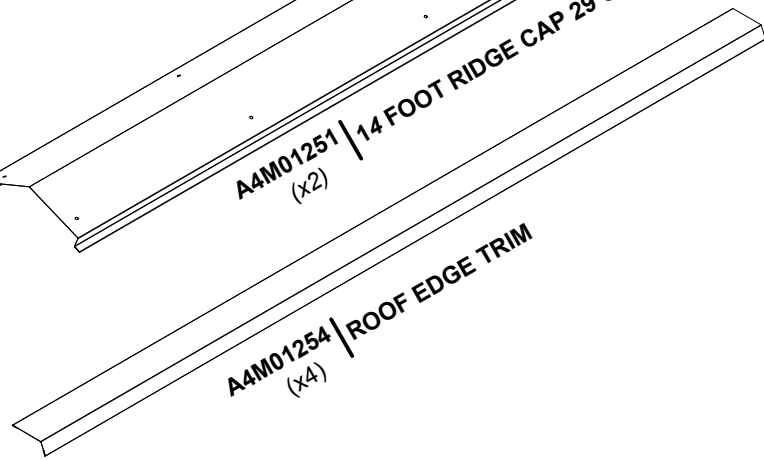
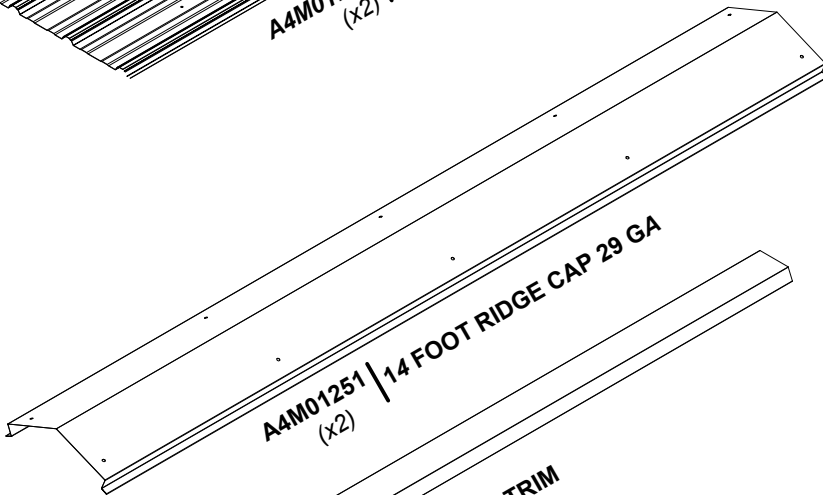
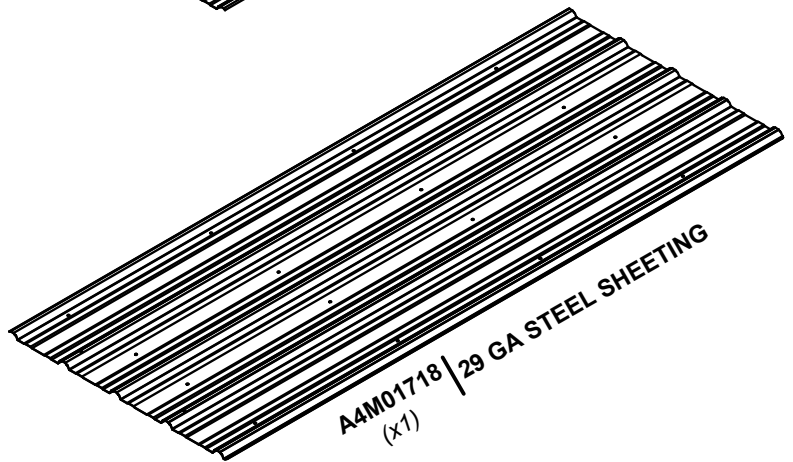
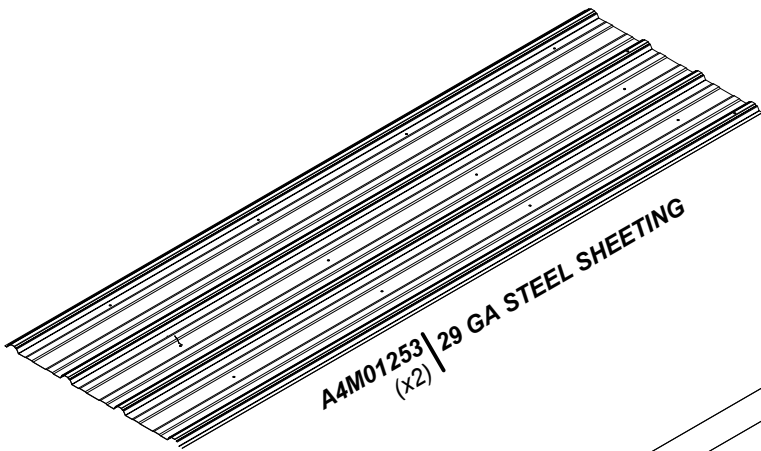
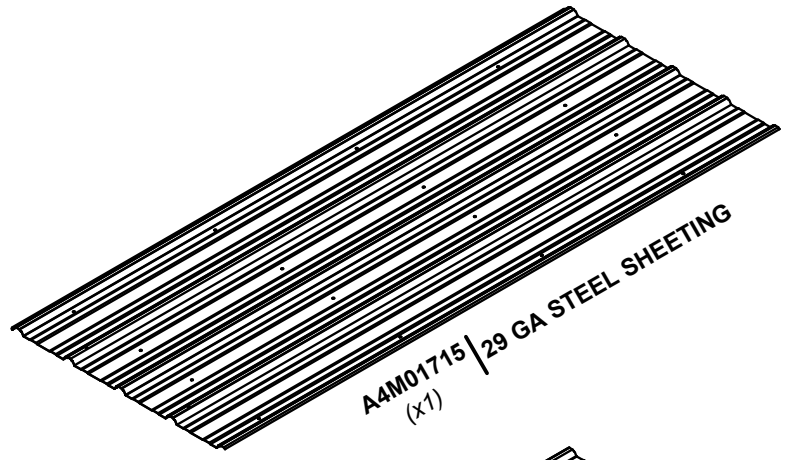
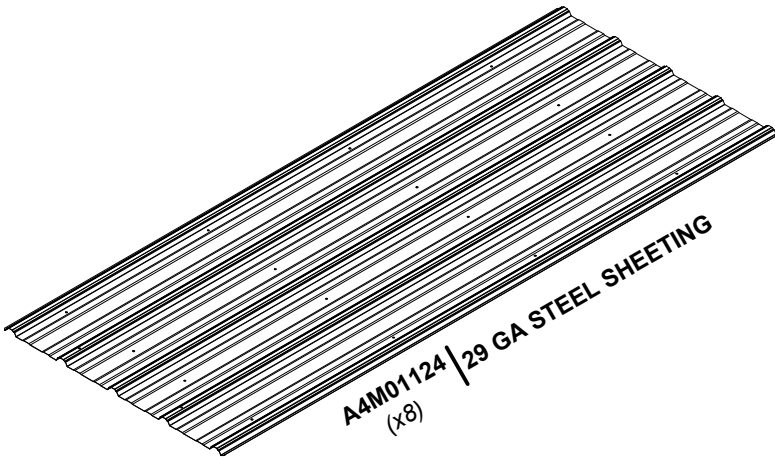

PRE-ASSEMBLY STEP 1 - SORTING PARTS

It is critical for ease of assembly that you take the time to sort and organize the wood and hardware.

WOOD PARTS:

- Organize wood parts by the three-digit, alpha-numeric number stamped on each board (ex. P01).
- If there are multiple boards with the same stamped number, stack those pieces together.
- Stamps can be found on the flat surface of the boards or on the end of the boards.
- Allow yourself plenty of room - the wood pieces can take up a significant amount of space.

NOTE: CARTONS ARE NOT ORGANIZED BY BOARD NUMBER.



HARDWARE PARTS:

- We recommend that you have a separate table to organize the hardware.
- Hardware bags are printed with a seven-digit, alpha-numeric part number.
- You can organize your hardware by part number or group by hardware type (i.e. bolts, nuts, etc.).
- During assembly you only need to reference the last four digits of the number.

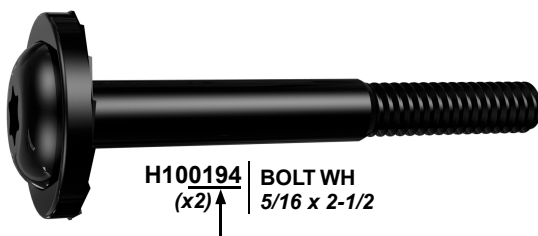

H100194 | BOLT WH
(x2) ↑ 5/16 x 2-1/2

PRE-ASSEMBLY STEP 2 - TOOLS REQUIRED



Cordless Drill
or Electric Drill



Drill
Attachments:
Phillips Head

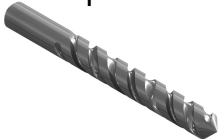

1/8", 3/16", 3/8" &
7/16" Drill Bits



Phillips Screw Driver

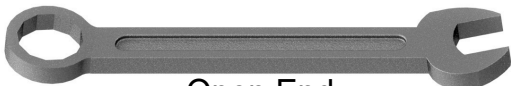

Open End
Wrenches 1/2" &
9/16"



3/8" Drive Ratchet, 1/2" &
7/16" STD Sockets 1/2" & 7/16"
Deep Sockets



Claw Hammer



Rubber Mallet
- Optional

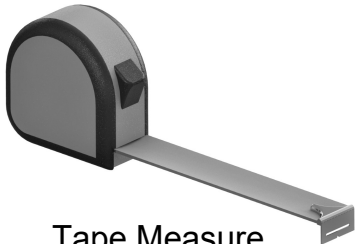

Tape Measure

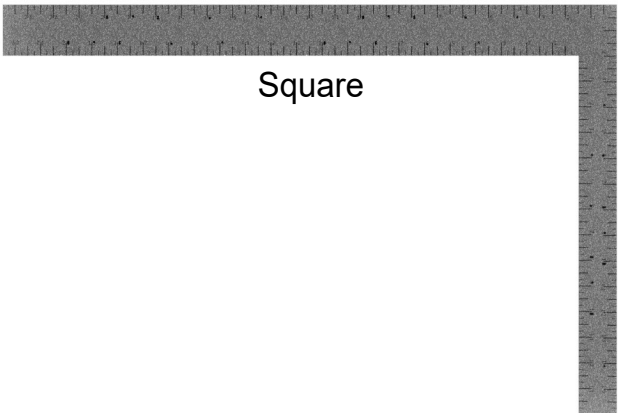

Square



Level 24"

PRE-ASSEMBLY STEP 3 - CHOOSE YOUR ASSEMBLY METHOD

There are several types of assembly instructions available to you.

1. Printed Assembly Manual included with your set
2. BILT APP - 3D interactive instructions
3. Combination of the Printed Manual and BILT APP (Note: Step numbers can differ between the two methods)



BILT.

Scan for easy
3D instructions

Download the BILT app
before you begin

Download on the
App Store

GET IT ON
Google Play

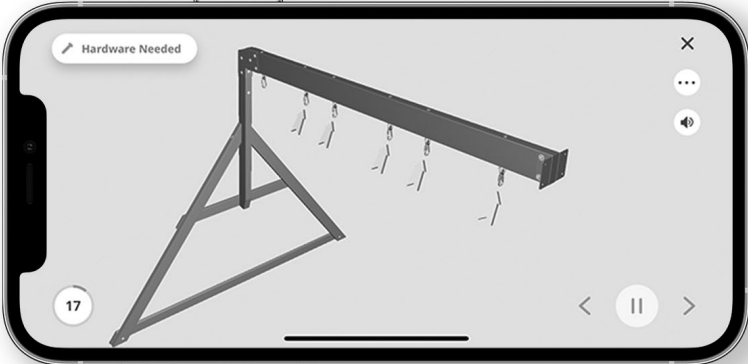

Hardware Needed

17

The image shows a smartphone screen displaying a 3D assembly instruction. The screen features a 3D model of a metal frame with a horizontal bar and several hanging components. The interface includes a 'Hardware Needed' button at the top left, a close button (X) at the top right, a menu button (three dots) and a volume icon below it, and a page indicator '17' in a circle at the bottom left. Navigation arrows and a play/pause button are visible at the bottom center of the screen.

STEP 4 - POST ASSEMBLY

QTY	PART NUMBER	DESCRIPTION
8	H100200	SCREW PFH 8x1 1/2 BLK



P01 | POST - W2A03501
(x1) | 6"x6"x89 1/2" (152x152x2274)

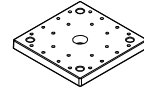

A6P00308 | 6x6 POST FOOT
(x2)



P02 | POST - W2A03502
(x1) | 6"x6"x89 1/2" (152x152x2274)

FOR EASE OF ASSEMBLY, WE RECOMMEND USING SAW HORSES FOR STEPS 4 - 11.

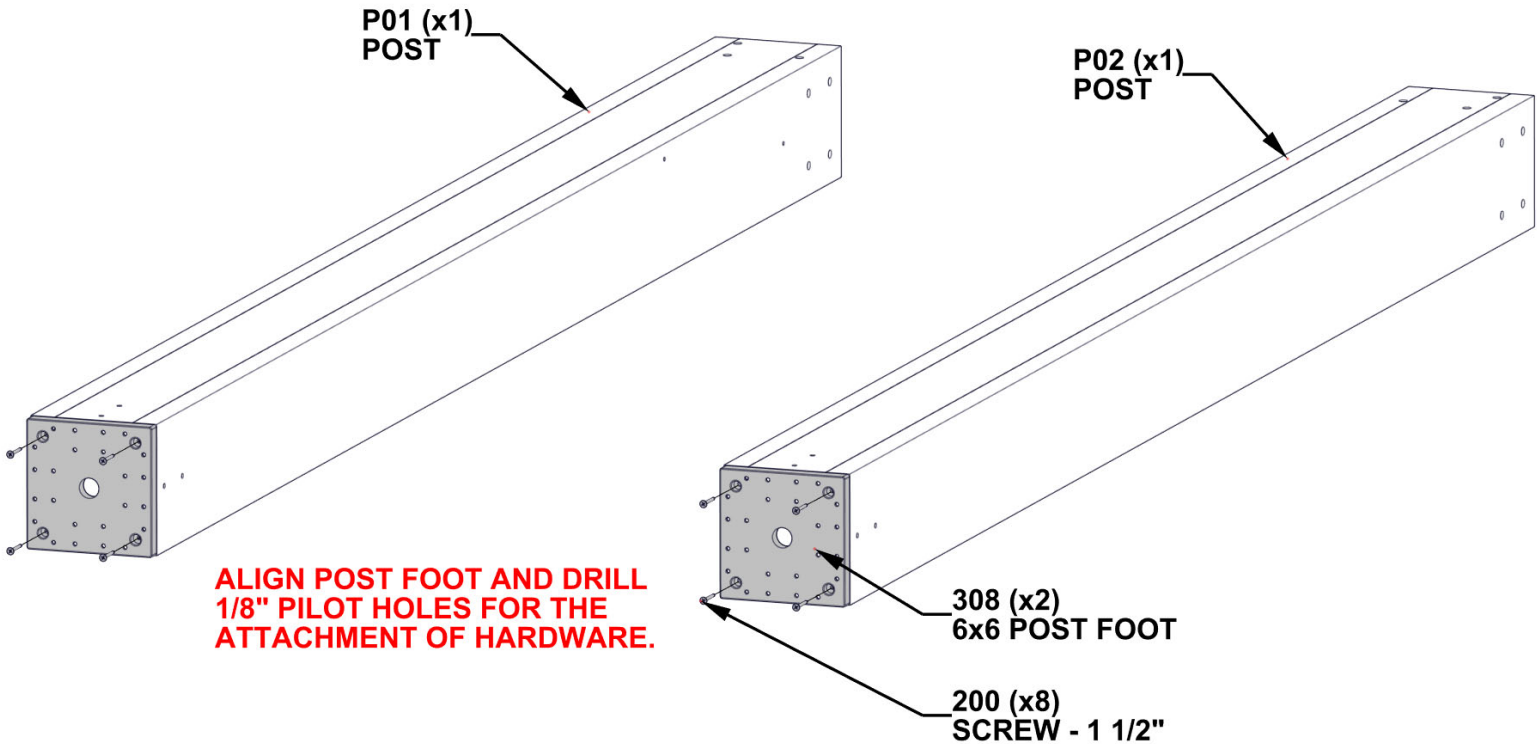

STEP 5 - GABLE ASSEMBLY

QTY	PART NUMBER	DESCRIPTION
2	H100483	SCREW PFH 8x2 1/4 BLK



D01 | GABLE BOARD - W4L16850
(x1) | 1 3/8"x5 1/4"x24 1/4" (36x134x615)

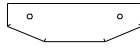

D05 | GABLE BOARD - W4L16854
(x1) | 1 3/8"x1 1/2"x5 1/4" (36x38x134)

ALIGN D05 WITH D01 ENSURING THAT BOTTOM FACES ARE FLUSH. DRILL 1/8" PILOT HOLES IN D01 USING D05 AS TEMPLATE.

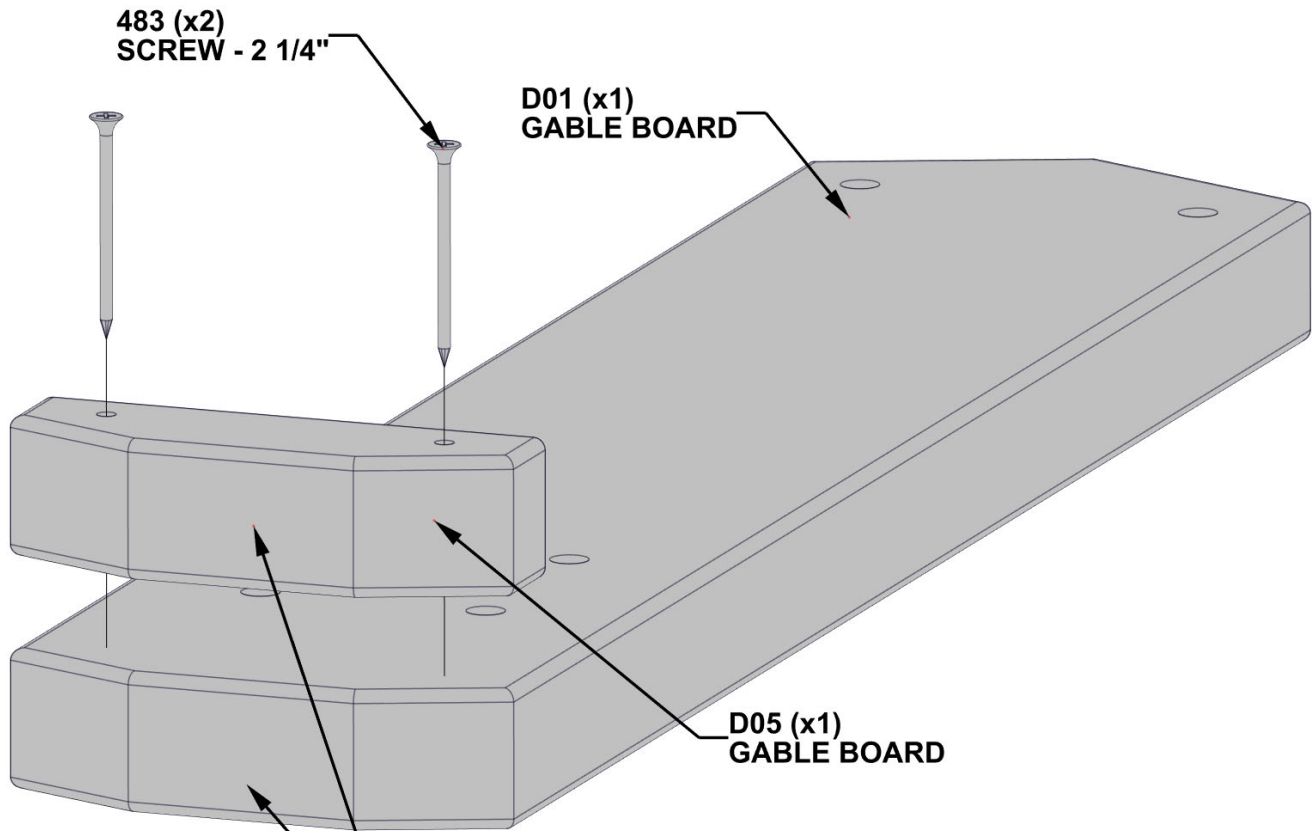

ENSURE FACES ARE FLUSH

STEP 6 - GABLE ASSEMBLY

QTY	PART NUMBER	DESCRIPTION
4	H100478	WASHER FLAT 8x27 BLK
4	H100479	NUT LOCK 5/16 BLK
4	H100881	BOLT WH 5/16x5 BLK

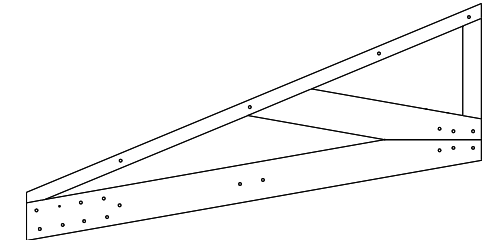

GT1 | GABLE TRUSS - W2A03503
(x2) 1 7/16"x33 5/8"x64 9/16" (36x854x1640)



D01 | GABLE BOARD - W4L16850
(x1) 1 3/8"x5 1/4"x24 1/4" (36x134x615)

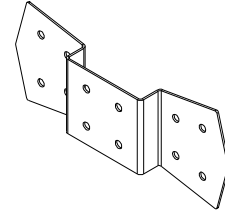

A4M01129 | GABLE BRACKET
(x2)

IF NEEDED FOR EASE OF ASSEMBLY, USE METAL BRACKET AS A GUIDE AND DRILL THROUGH USING A 7/16" - (10mm) DRILL BIT, THEN ASSEMBLE.

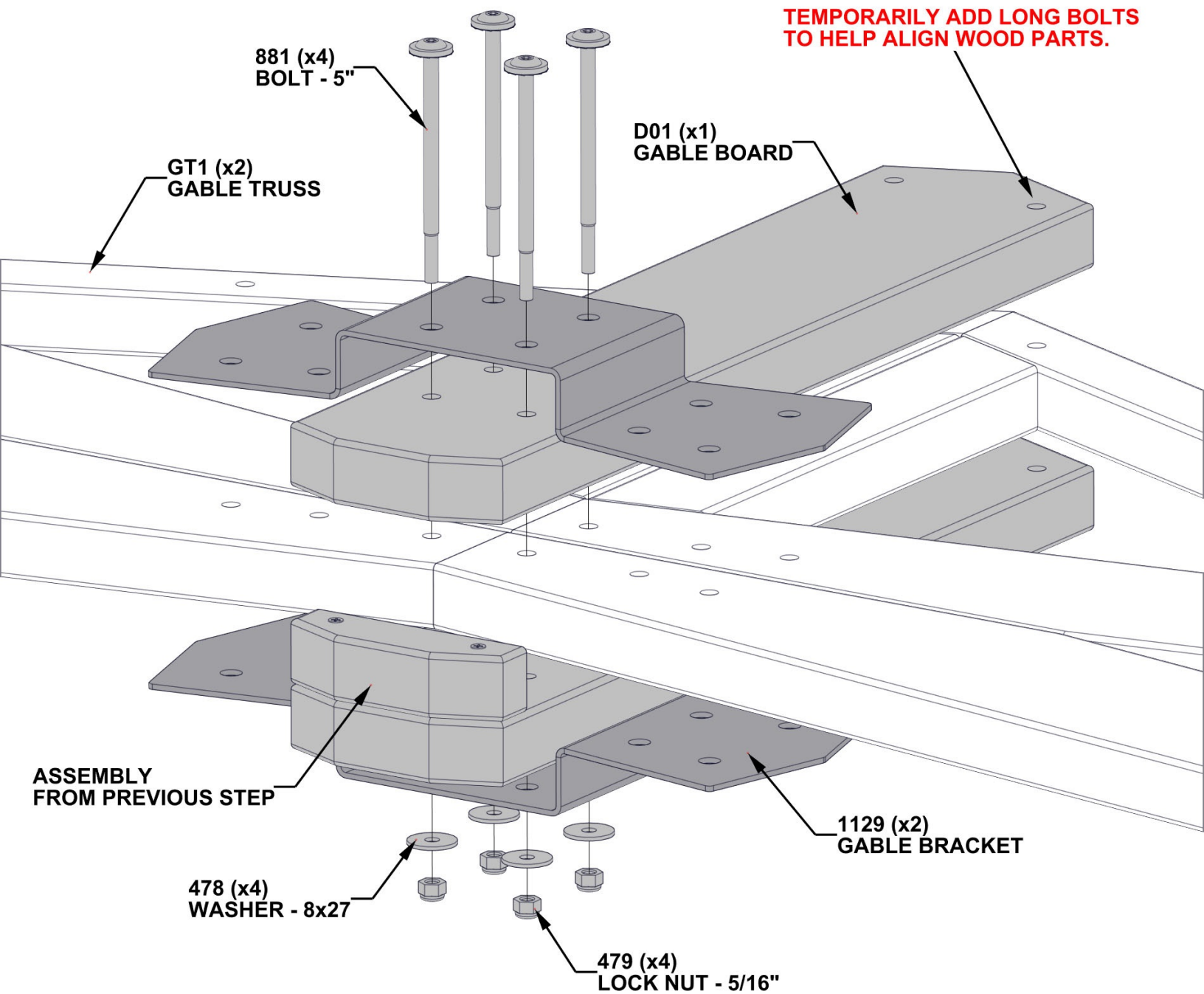

STEP 7 - GABLE ASSEMBLY

QTY	PART NUMBER	DESCRIPTION
8	H100205	BOLT WH 5/16x2 1/4 BLK
8	H100478	WASHER FLAT 8x27 BLK
8	H100479	NUT LOCK 5/16 BLK

IF NEEDED FOR EASE OF ASSEMBLY, USE METAL BRACKET AS A GUIDE AND DRILL THROUGH USING A 7/16" - (10mm) DRILL BIT, THEN ASSEMBLE.

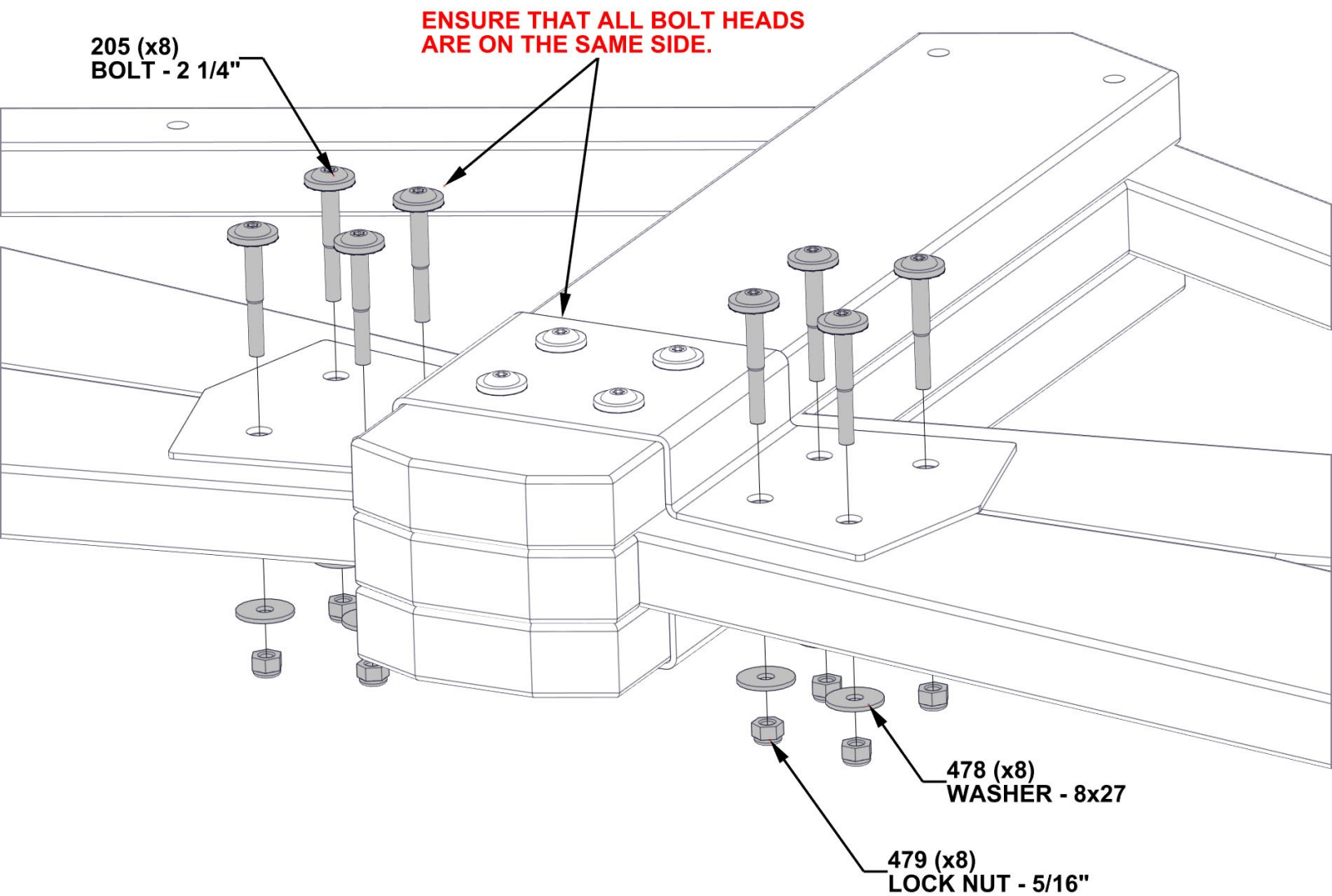

STEP 8A - GABLE ASSEMBLY

P01 | POST - W2A03501
(x1) | 6"x6"x89 1/2" (152x152x2274)

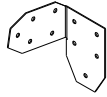

A4M01232 | LEFT ANGLE BRACKET
(x1)

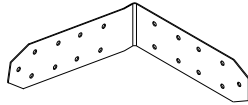

D02 | TOP RAIL - W4L16886
(x1) | 1 3/8"x5 1/4"x53 3/4" (36x134x1366)



D07 | TOP RAIL - W4L16888
(x1) | 1 3/8"x5 1/4"x82 1/4" (36x134x2091)

A4M01302 | LEFT OUTSIDE BRACKET
(x1)

QTY	PART NUMBER	DESCRIPTION
5	H100205	BOLT WH 5/16x2 1/4 BLK
8	H100379	T-NUT 5/16 BLK
5	H100416	BOLT WH 5/16x3 BLK
1	H100471	LAG SCREW WH 5/16x1 1/2 BLK
10	H100478	WASHER FLAT 8x27 BLK
9	H100479	NUT LOCK 5/16 BLK
1	H100659	LAG SCREW HEX 5/16x1 1/2 BLK
3	H101046	BOLT WH 5/16x7 1/2 BLK
4	H101047	BOLT WH 5/16x9 3/4 BLK

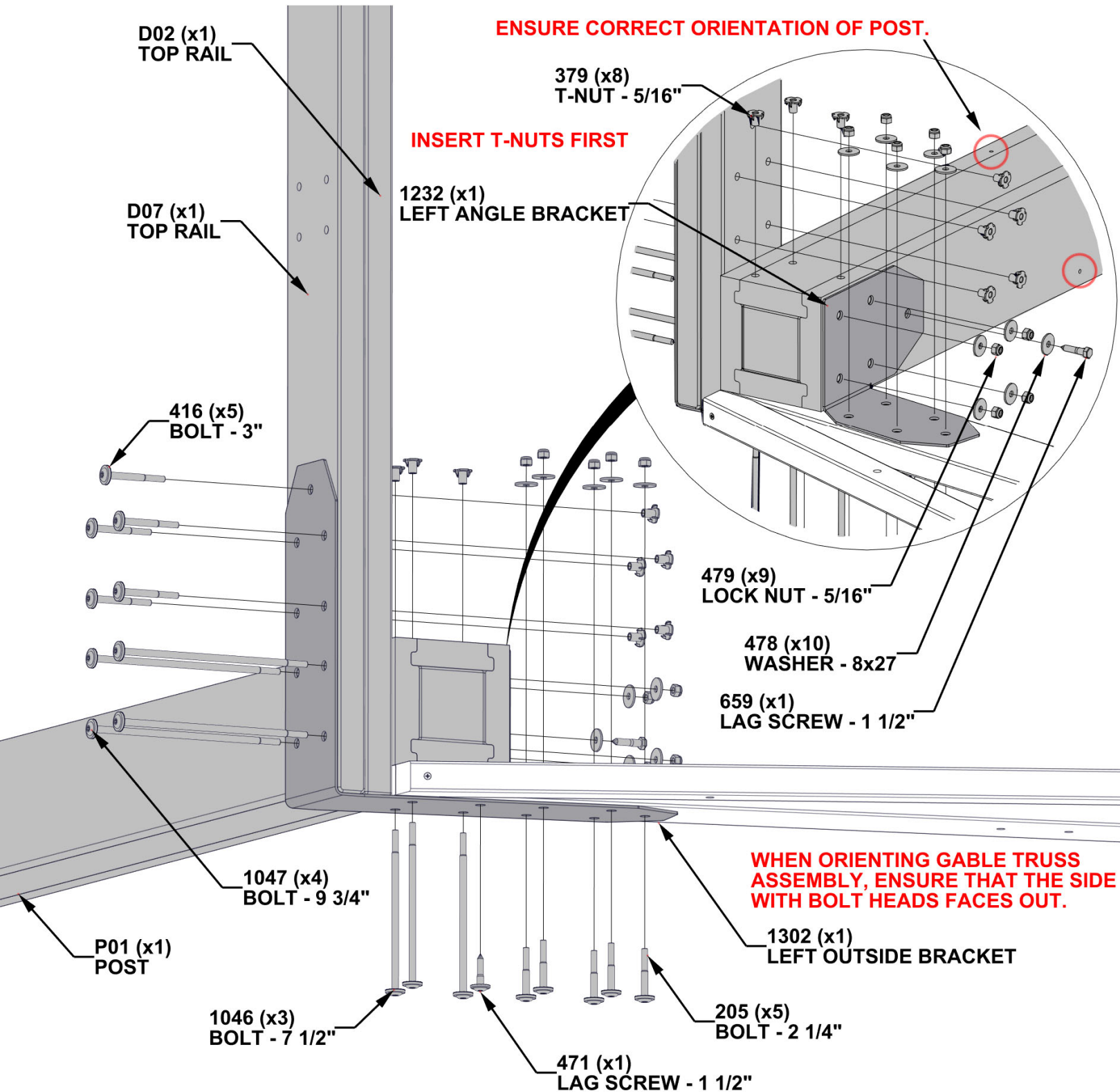

STEP 8B - GABLE ASSEMBLY

P02 | POST - W2A03502
(x1) | 6"x6"x89 1/2" (152x152x2274)

D02 | TOP RAIL - W4L16886
(x1) | 1 3/8"x5 1/4"x53 3/4" (36x134x1366)

D07 | TOP RAIL - W4L16888
(x1) | 1 3/8"x5 1/4"x82 1/4" (36x134x2091)

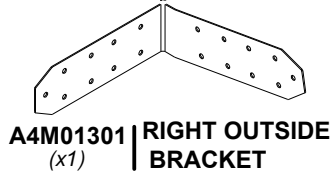
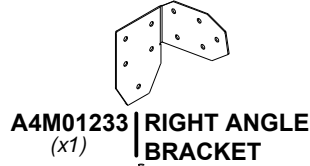

QTY	PART NUMBER	DESCRIPTION
5	H100205	BOLT WH 5/16x2 1/4 BLK
8	H100379	T-NUT 5/16 BLK
5	H100416	BOLT WH 5/16x3 BLK
1	H100471	LAG SCREW WH 5/16x1 1/2 BLK
10	H100478	WASHER FLAT 8x27 BLK
9	H100479	NUT LOCK 5/16 BLK
1	H100659	LAG SCREW HEX 5/16x1 1/2 BLK
3	H101046	BOLT WH 5/16x7 1/2 BLK
4	H101047	BOLT WH 5/16x9 3/4 BLK

ENSURE CORRECT ORIENTATION OF POST.

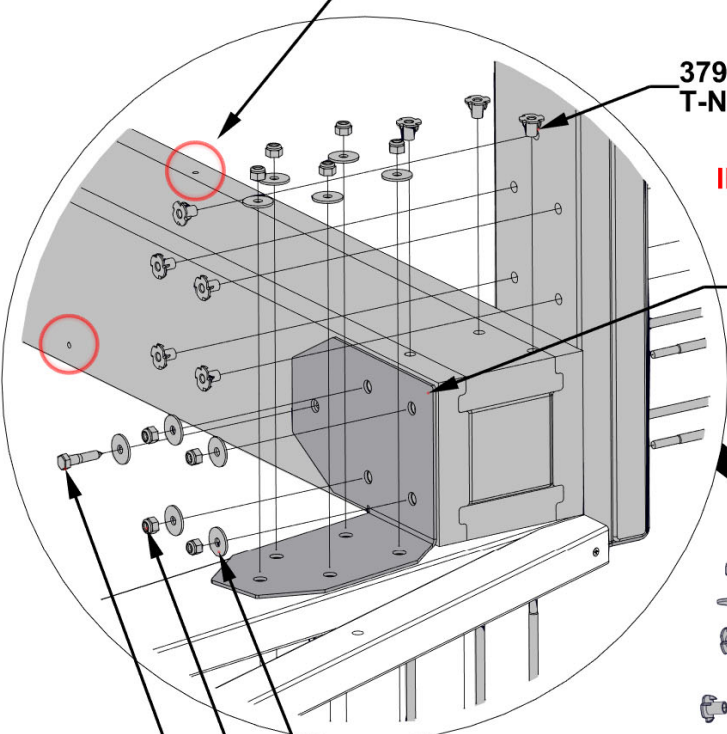

INSERT T-NUTS FIRST

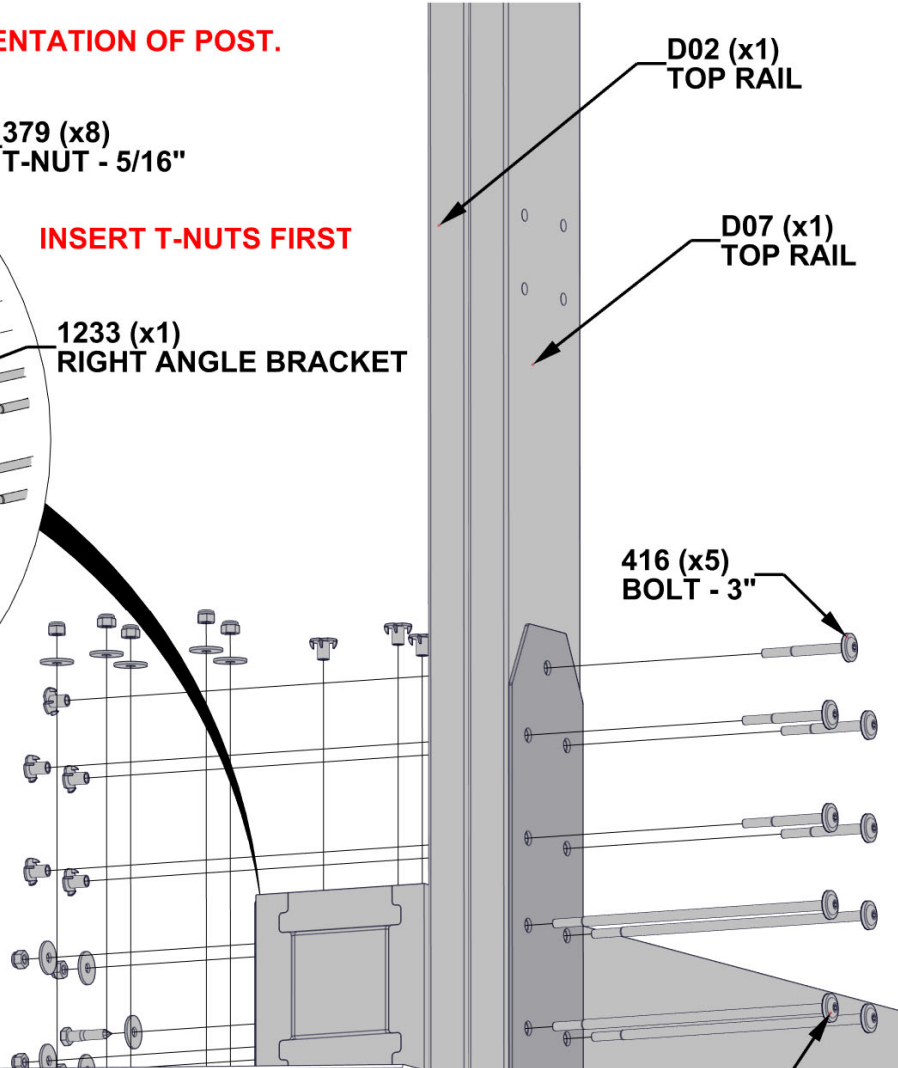

WHEN ORIENTING GABLE TRUSS ASSEMBLY, ENSURE THAT THE SIDE WITH BOLT HEADS FACES OUT.

1301 (x1)
RIGHT OUTSIDE BRACKET

205 (x5)
BOLT - 2 1/4"

471 (x1)
LAG SCREW - 1 1/2"

1046 (x3)
BOLT - 7 1/2"

STEP 9 - GABLE ASSEMBLY

QTY	PART NUMBER	DESCRIPTION
4	H100195	BOLT WH 5/16x2 3/4 BLK
4	H100198	WASHER LOCK EXT 8x19
4	H100379	T-NUT 5/16 BLK
2	H100405	WASHER LOCK EXT 6x15
2	H100792	LAG SCREW WH 1/4x3 BLK



CA01 | CORBEL - W2A03504
(x1) | 1 7/16"x5 3/8"x46 1/16" (36x136x1160)



D06 | CORBEL - W4L16855
(x3) | 1 3/8"x5 1/4"x45 5/8" (36x134x1160)

TWO D06 BOARDS WILL BE USED FOR OTHER END GABLE.

INSERT T-NUTS FIRST

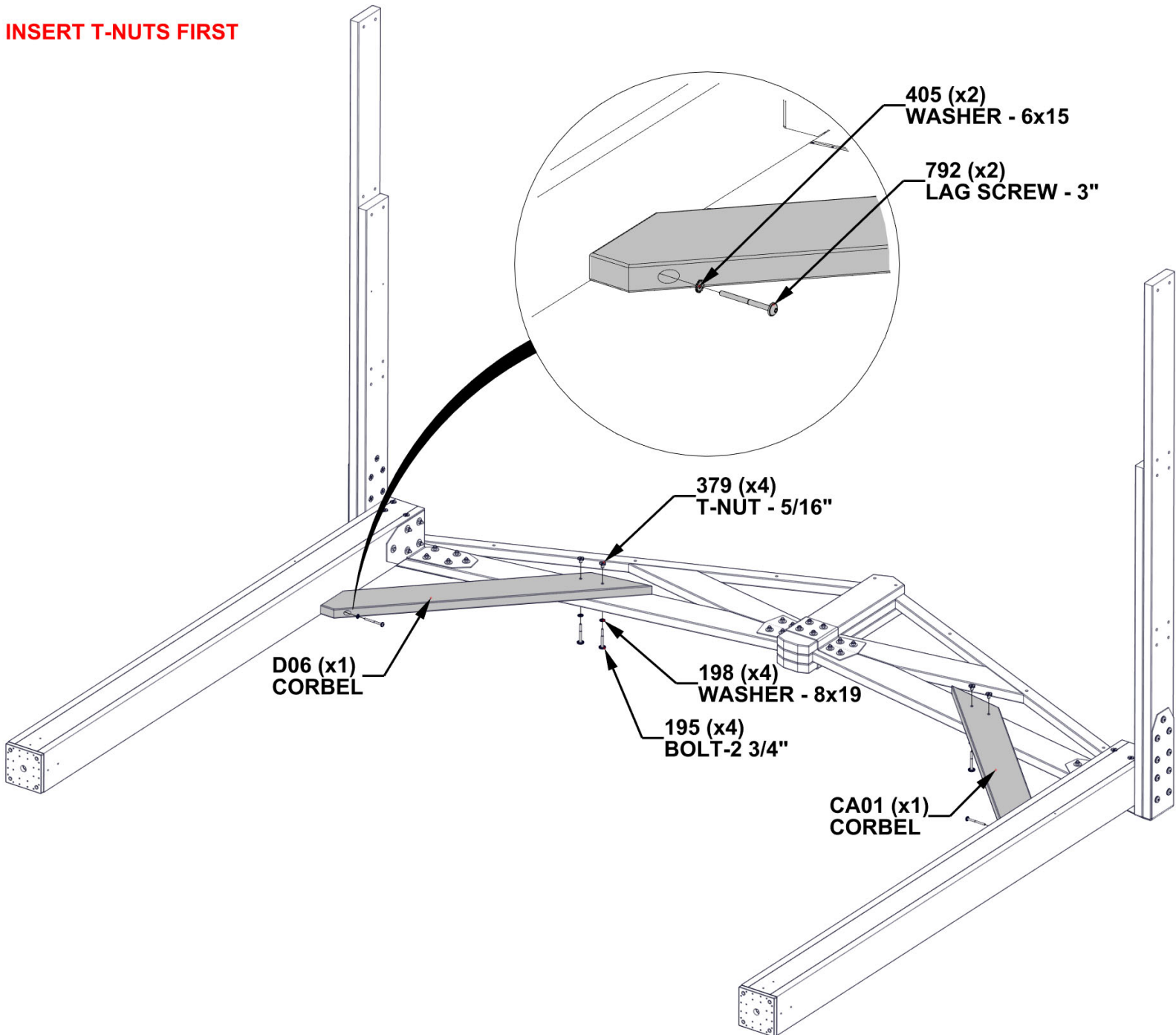

**REPEAT POST AND GABLE ASSEMBLY
STEPS 4 THROUGH 9**

STEP 10 - GAZEBO ASSEMBLY

QTY	PART NUMBER	DESCRIPTION
4	H100195	BOLT WH 5/16x2 3/4 BLK
12	H100198	WASHER LOCK EXT 8x19
4	H100201	SCREW PFH 8x2 1/2 BLK
12	H100379	T-NUT 5/16 BLK
2	H100405	WASHER LOCK EXT 6x15
8	H100513	BOLT WH 5/16x4 1/4 BLK
2	H100792	LAG SCREW WH 1/4x3 BLK



D04 CORBEL - W4L16853
(x2) | 1 3/8"x5 1/4"x35 7/8" (36x134x910)

INSERT T-NUTS FIRST

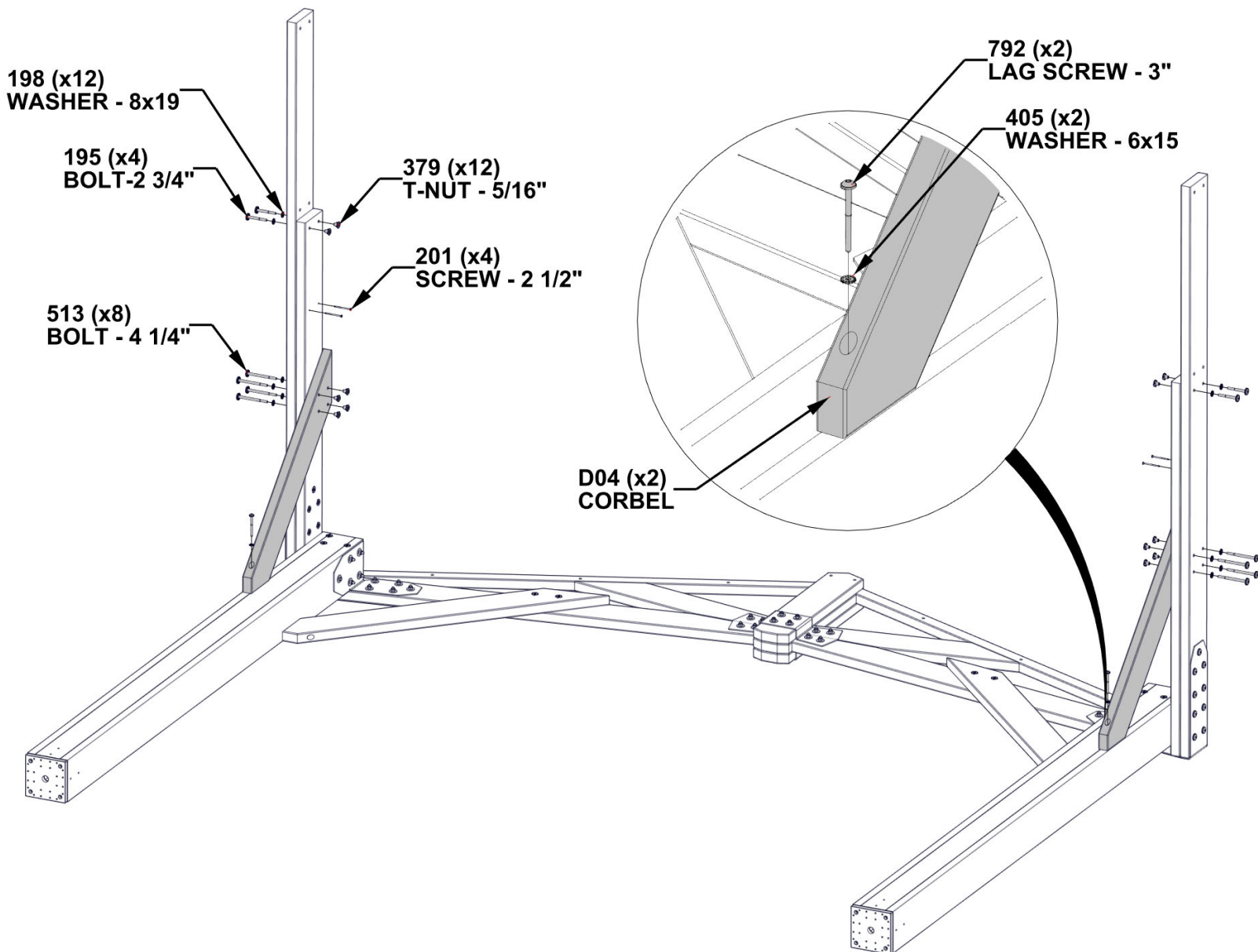

STEP 11 - GAZEBO ASSEMBLY

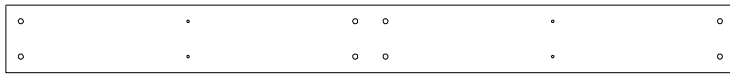

D03 | TOP RAIL - W4L16887
(x2) | 1 3/8"x5 1/4"x57" (36x134x1448)

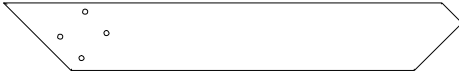

D04 | CORBEL - W4L16853
(x2) | 1 3/8"x5 1/4"x35 7/8" (36x134x910)

QTY	PART NUMBER	DESCRIPTION
12	H100195	BOLT WH 5/16x2 3/4 BLK
20	H100198	WASHER LOCK EXT 8x19
8	H100201	SCREW PFH 8x2 1/2 BLK
20	H100379	T-NUT 5/16 BLK
2	H100405	WASHER LOCK EXT 6x15
8	H100513	BOLT WH 5/16x4 1/4 BLK
2	H100792	LAG SCREW WH 1/4x3 BLK

INSERT T-NUTS FIRST

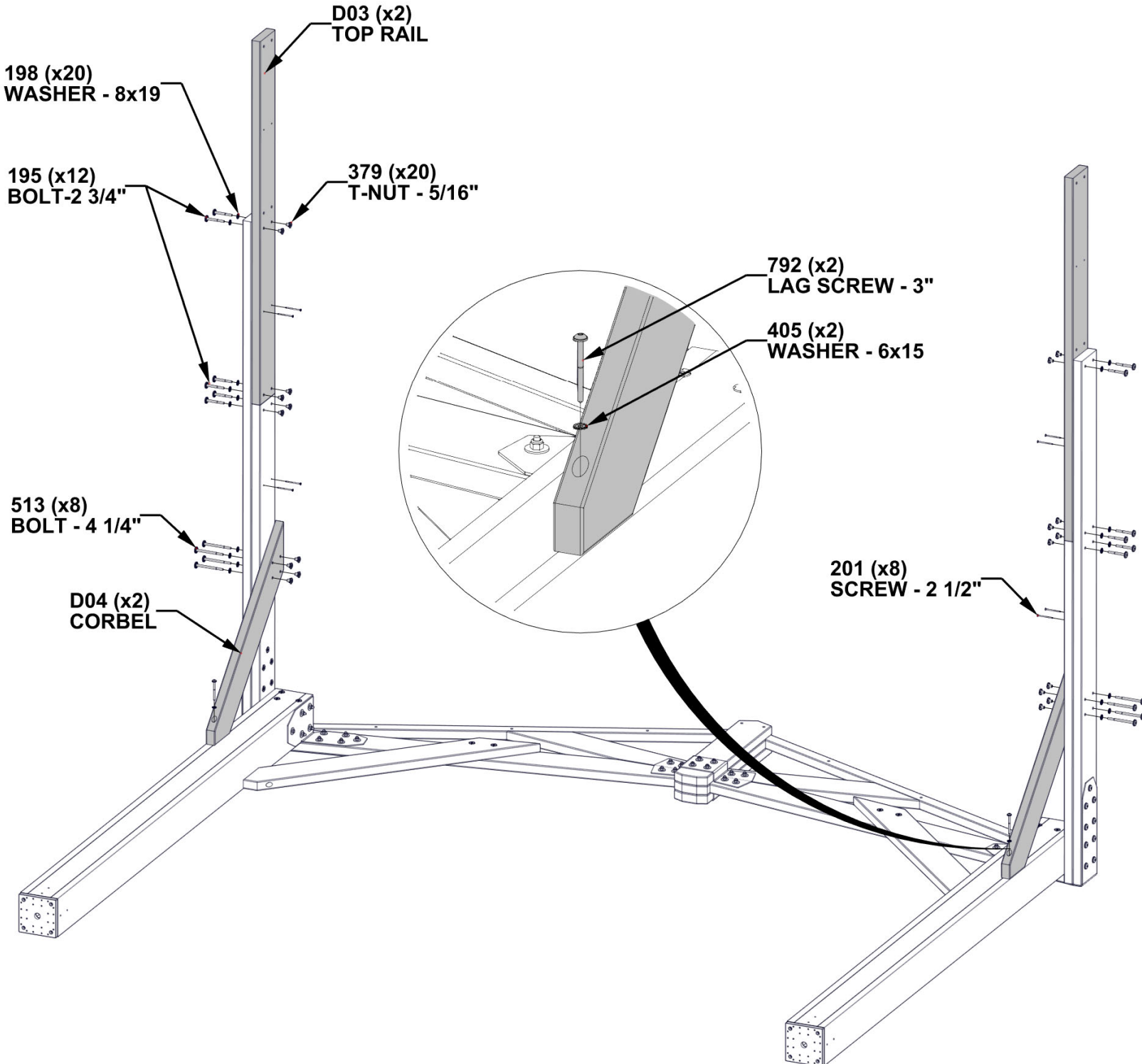

STEP 12 - GAZEBO ASSEMBLY

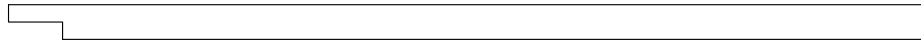

H08 | NOTCHED SUPPORT BOARD - W4L16915
(x2) | 1"x3 3/8"x89 1/2" (24x86x2274)

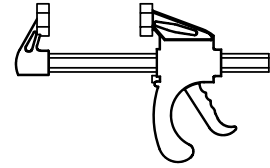

A6P00460 | 6" QUICK RELEASE
(x2) | BAR CLAMP

USING THE INCLUDED CLAMPS AND H08 BOARDS, STAND UP ONE GABLE END AND SECURELY CLAMP AS SHOWN. ADDITIONAL HELPERS ARE RECOMMENDED FOR THIS STEP.

460 (x2)
6" QUICK RELEASE BAR CLAMP

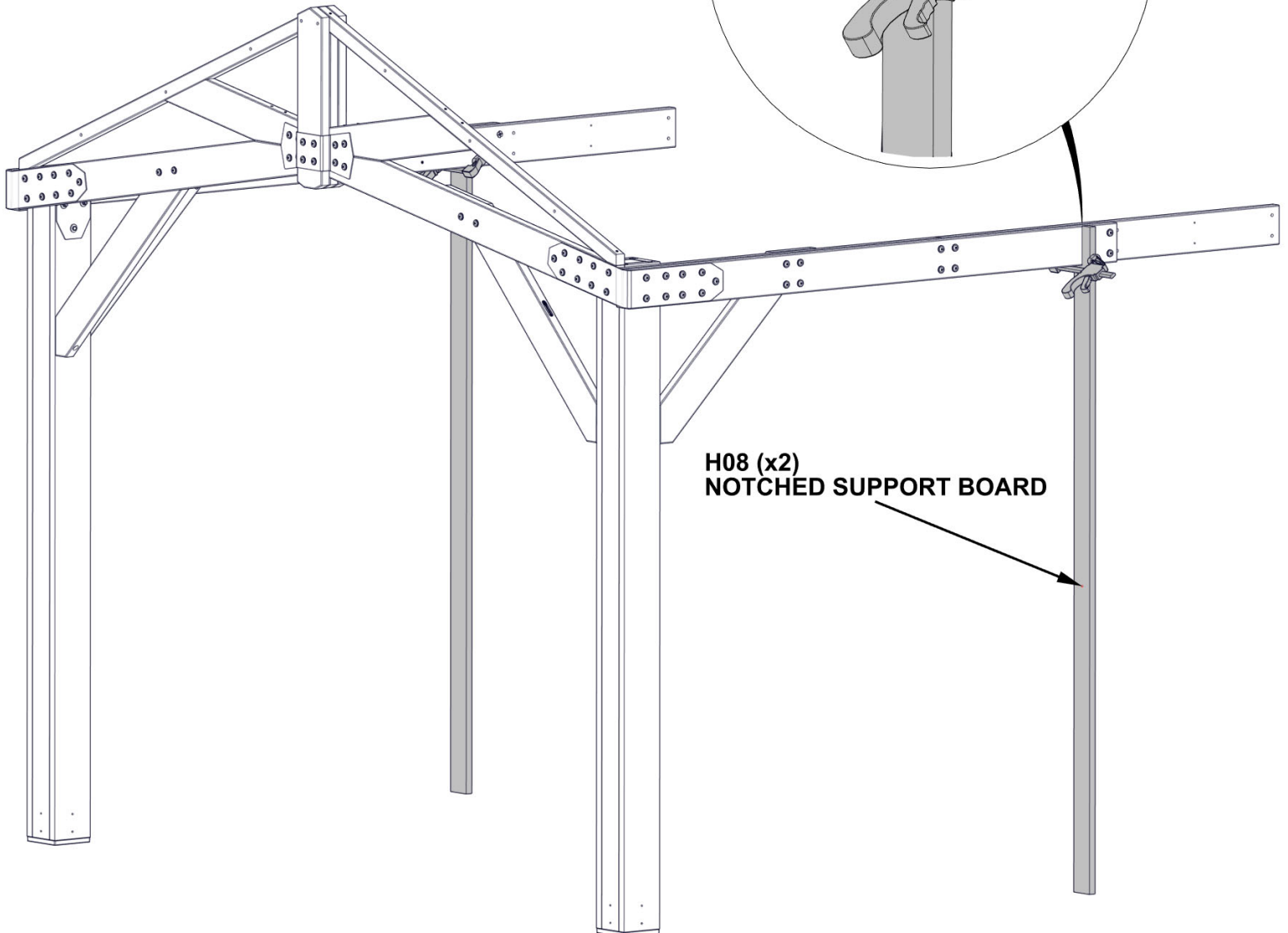
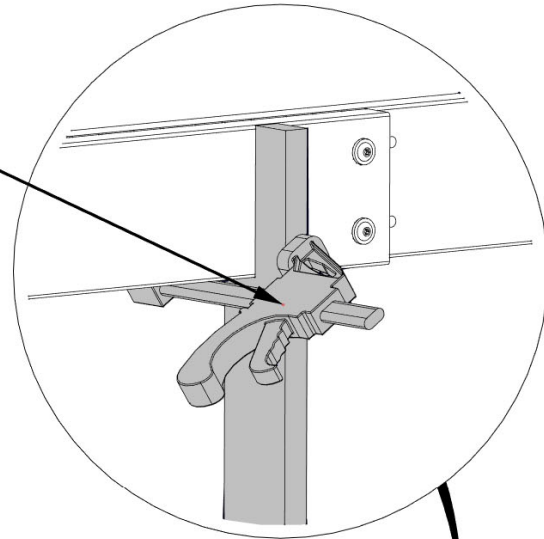

H08 (x2)
NOTCHED SUPPORT BOARD

STEP 13 - GAZEBO ASSEMBLY

QTY	PART NUMBER	DESCRIPTION
8	H100195	BOLT WH 5/16x2 3/4 BLK
8	H100198	WASHER LOCK EXT 8x19
4	H100201	SCREW PFH 8x2 1/2 BLK
8	H100379	T-NUT 5/16 BLK

INSERT T-NUTS FIRST

STAND UP OTHER GABLE END AND ATTACH HARDWARE AS SHOWN. ONCE ALL HARDWARE IS SECURELY ATTACHED, REMOVE CLAMPS AND H08 BOARDS.

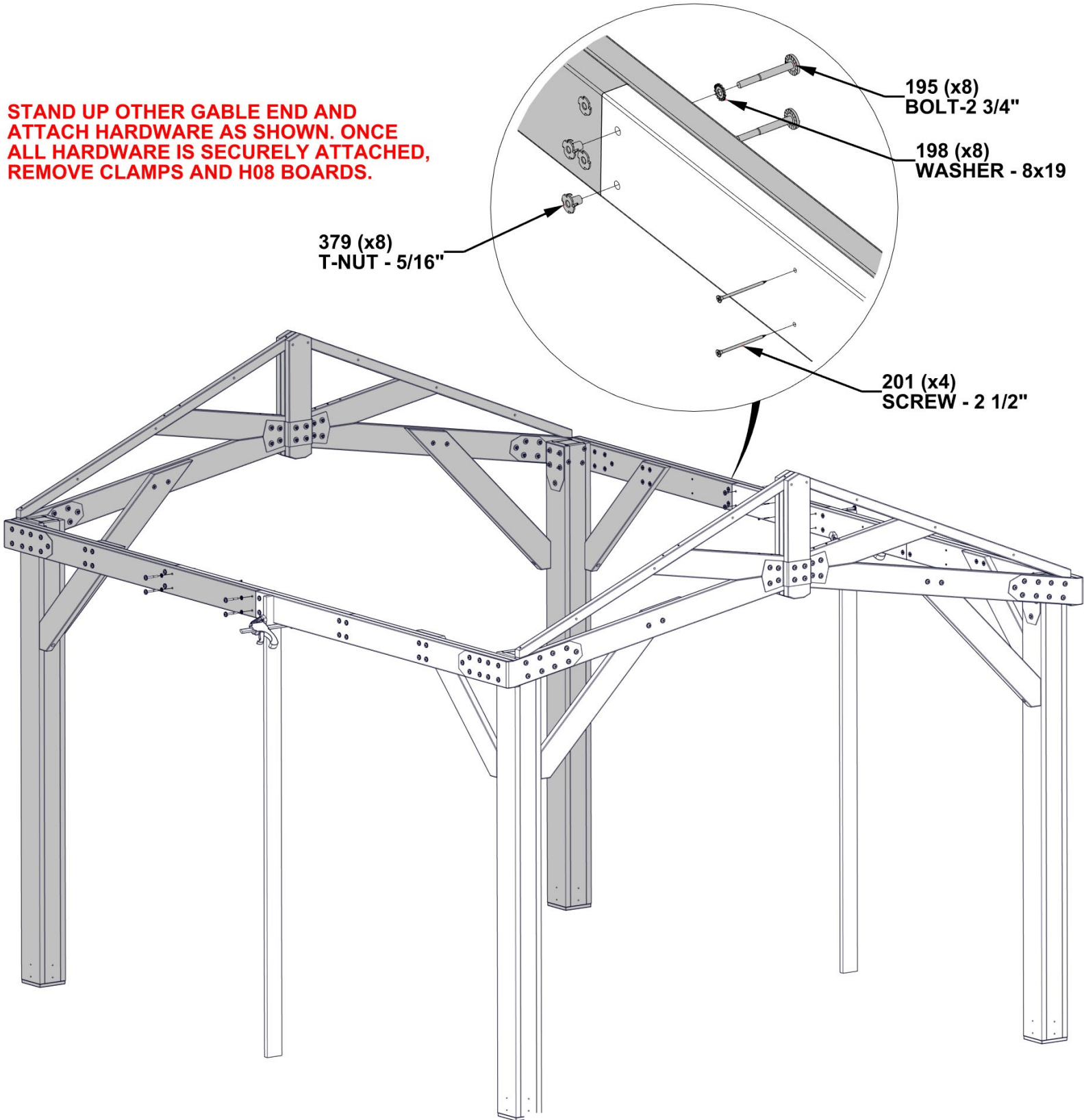

STEP 14 - GAZEBO ASSEMBLY

QTY	PART NUMBER	DESCRIPTION
16	H100201	SCREW PFH 8x2 1/2 BLK

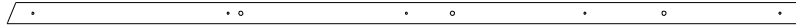

E02 | TRUSS - W4L16859
(x4) | 1 7/16"x1 15/16"x74 15/16" (36x50x1902)

FLUSH TOPS

**ALIGN HOLES FOR
CORRECT ORIENTATION.**

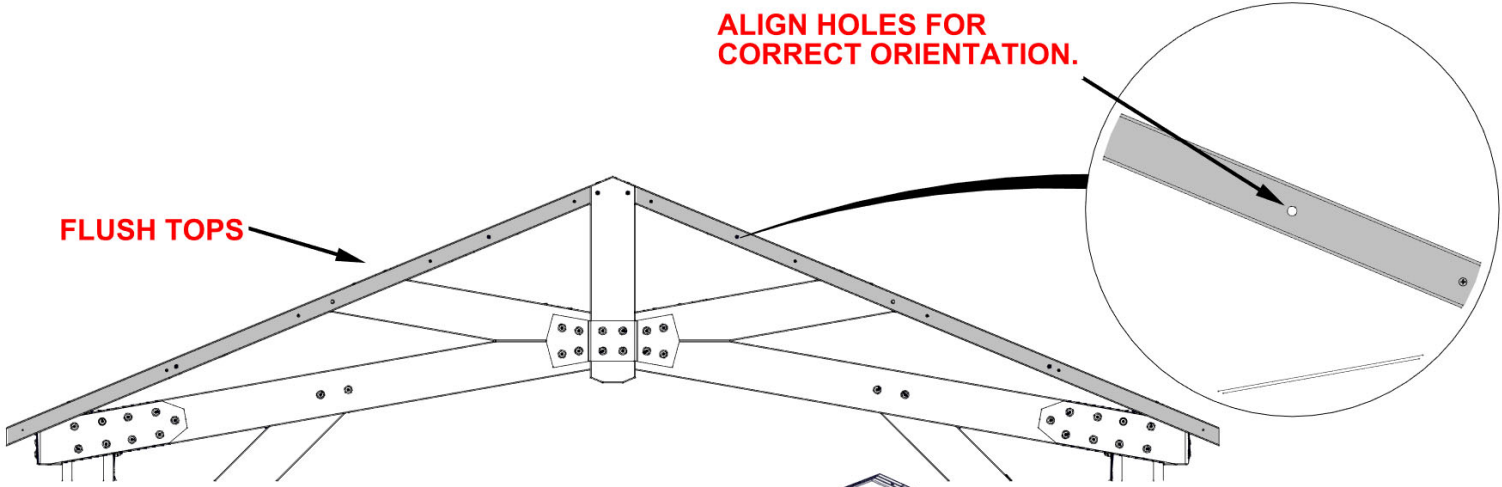

**201 (x16)
SCREW - 2 1/2"**

**E02 (x4)
TRUSS**

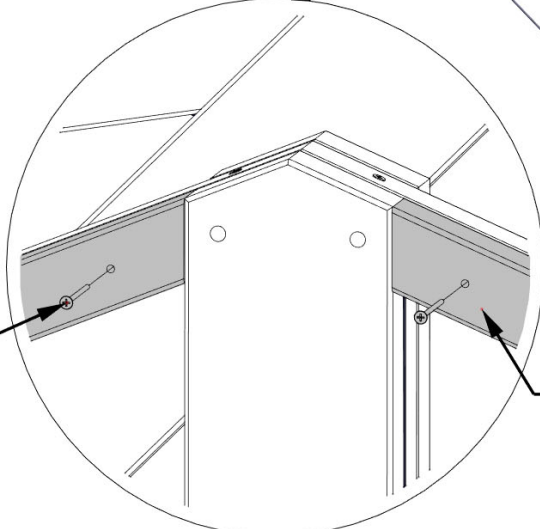

STEP 15 - GAZEBO ASSEMBLY

QTY	PART NUMBER	DESCRIPTION
4	H100201	SCREW PFH 8x2 1/2 BLK
12	H100405	WASHER LOCK EXT 6x15
12	H100564	LAG SCREW WH 1/4x4 BLK

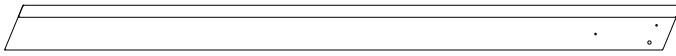

GP1 | GABLE PANEL - W2A03499
(x2) | 2 13/16"x5 1/4"x80 3/16" (72x134x2037)

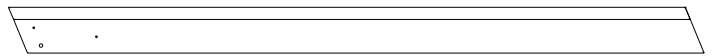

GP2 | GABLE PANEL - W2A03500
(x2) | 2 13/16"x5 1/4"x80 3/16" (72x134x2037)

TEMPORARILY INSERT 354 BOLTS TO ALIGN GABLE PANEL WITH GABLE.

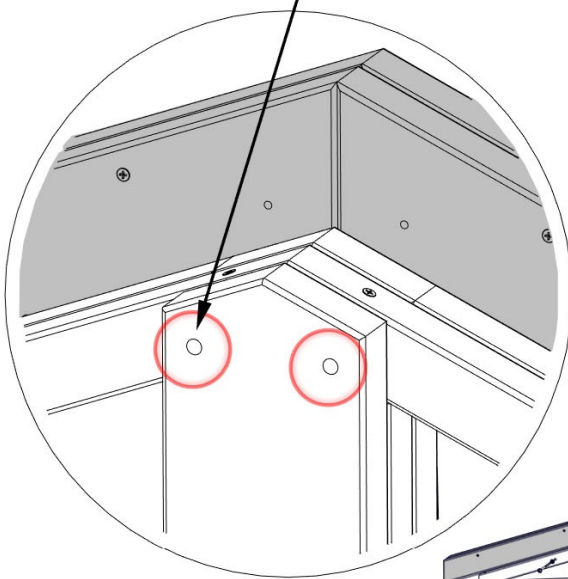

405 (x12)
WASHER - 6x15

564 (x12)
LAG SCREW - 4"

201 (x4)
SCREW - 2 1/2"

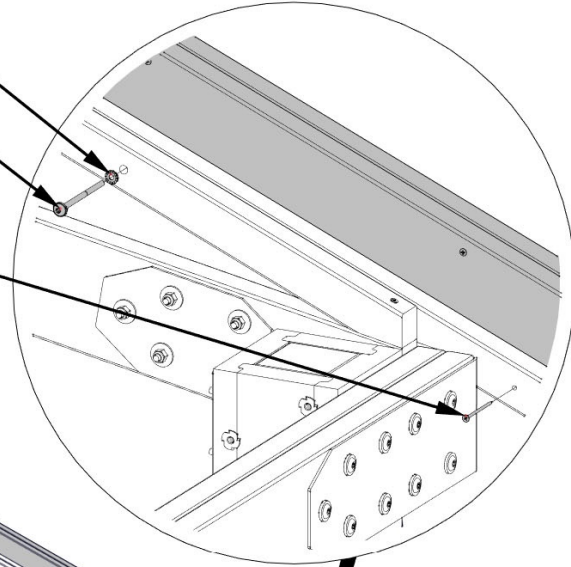

GP1 (x2)
GABLE PANEL

GP2 (x2)
GABLE PANEL

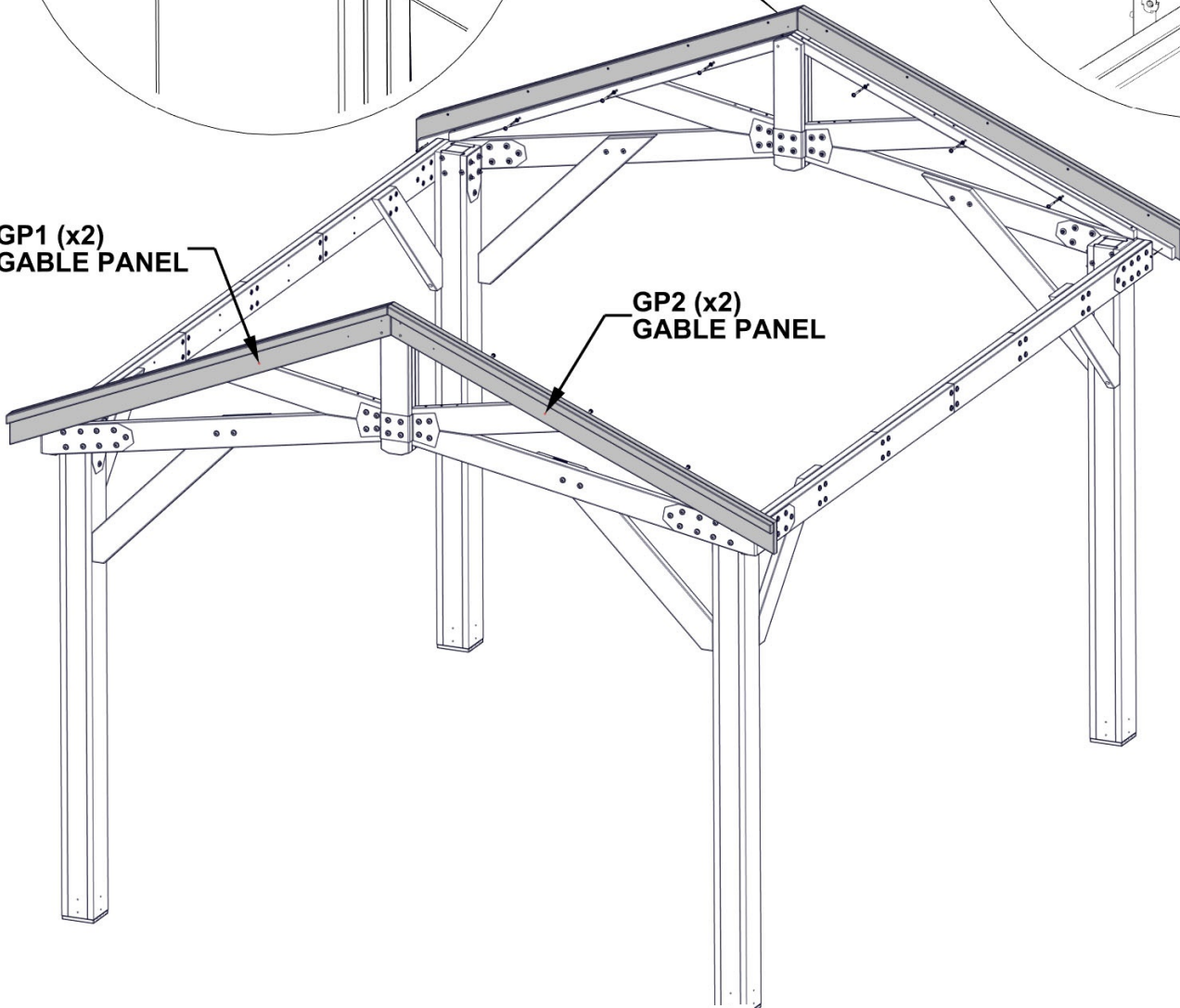

STEP 16 - GAZEBO ASSEMBLY

QTY	PART NUMBER	DESCRIPTION
4	H100200	SCREW PFH 8x1 1/2 BLK
4	H100354	BOLT WH 5/16x6 1/2 BLK
8	H100471	LAG SCREW WH 5/16x1 1/2 BLK
4	H100478	WASHER FLAT 8x27 BLK
4	H100479	NUT LOCK 5/16 BLK

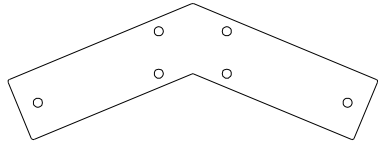

A4M01130 | GABLE BRACKET
(x2)

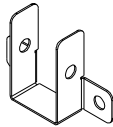

A4M01148 | TRUSS BRACKET
(x2)

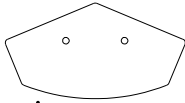

A4M01147 | PEAK SEAM BRACKET
(x2)

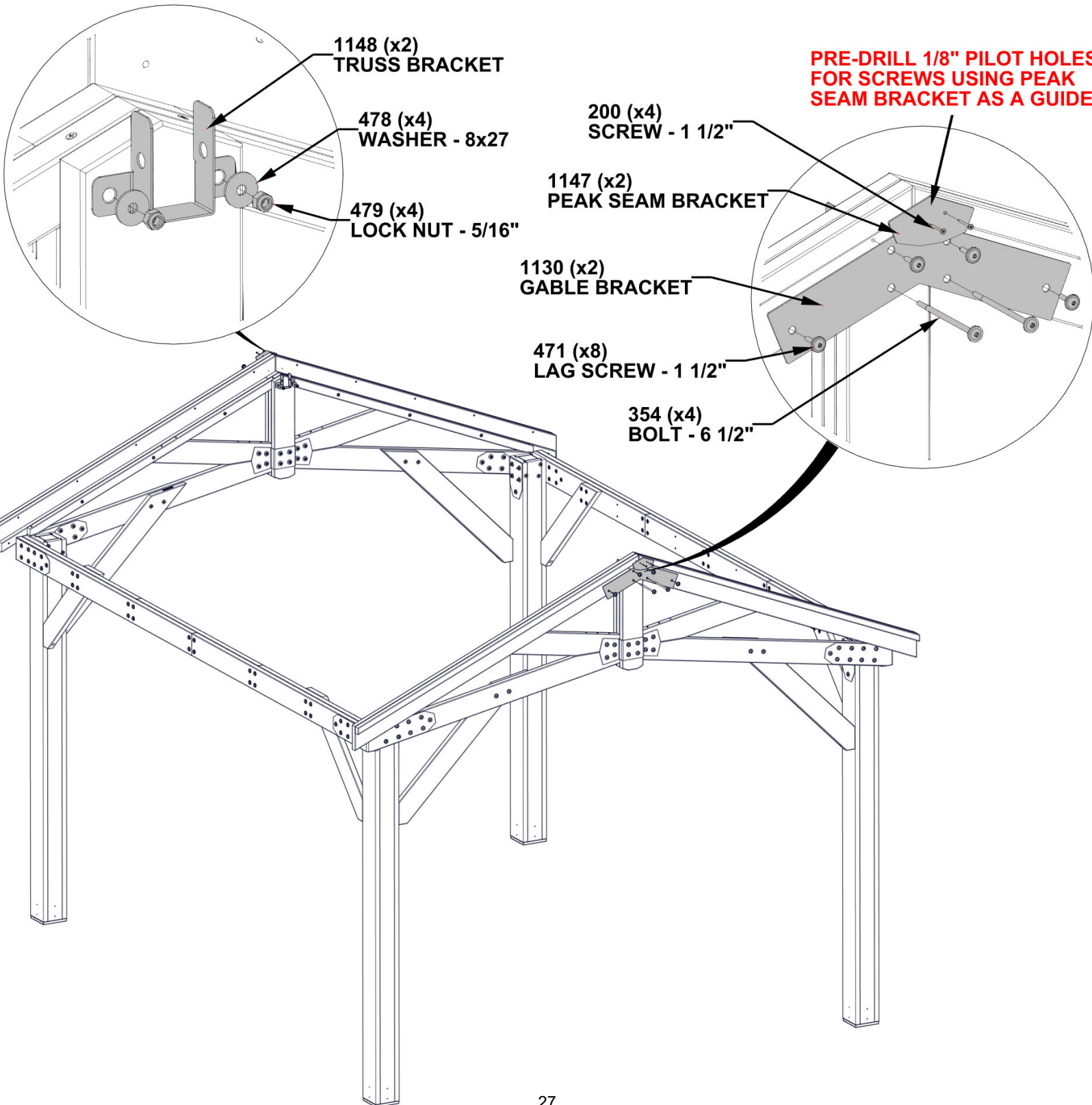

STEP 17 - RAFTER ASSEMBLY

QTY	PART NUMBER	DESCRIPTION
8	H100198	WASHER LOCK EXT 8x19
16	H100379	T-NUT 5/16 BLK
10	H100382	SCREW PFH 8x1 3/4 BLK
8	H100459	BOLT WH 5/16x1 1/4 BLK

H04 | RAFTER - W4L16893
(x2) | 1"x3 3/8"x89 1/4" (24x86x2267)

H05 | RAFTER - W4L16894
(x2) | 1"x3 3/8"x69 1/2" (24x86x1766)

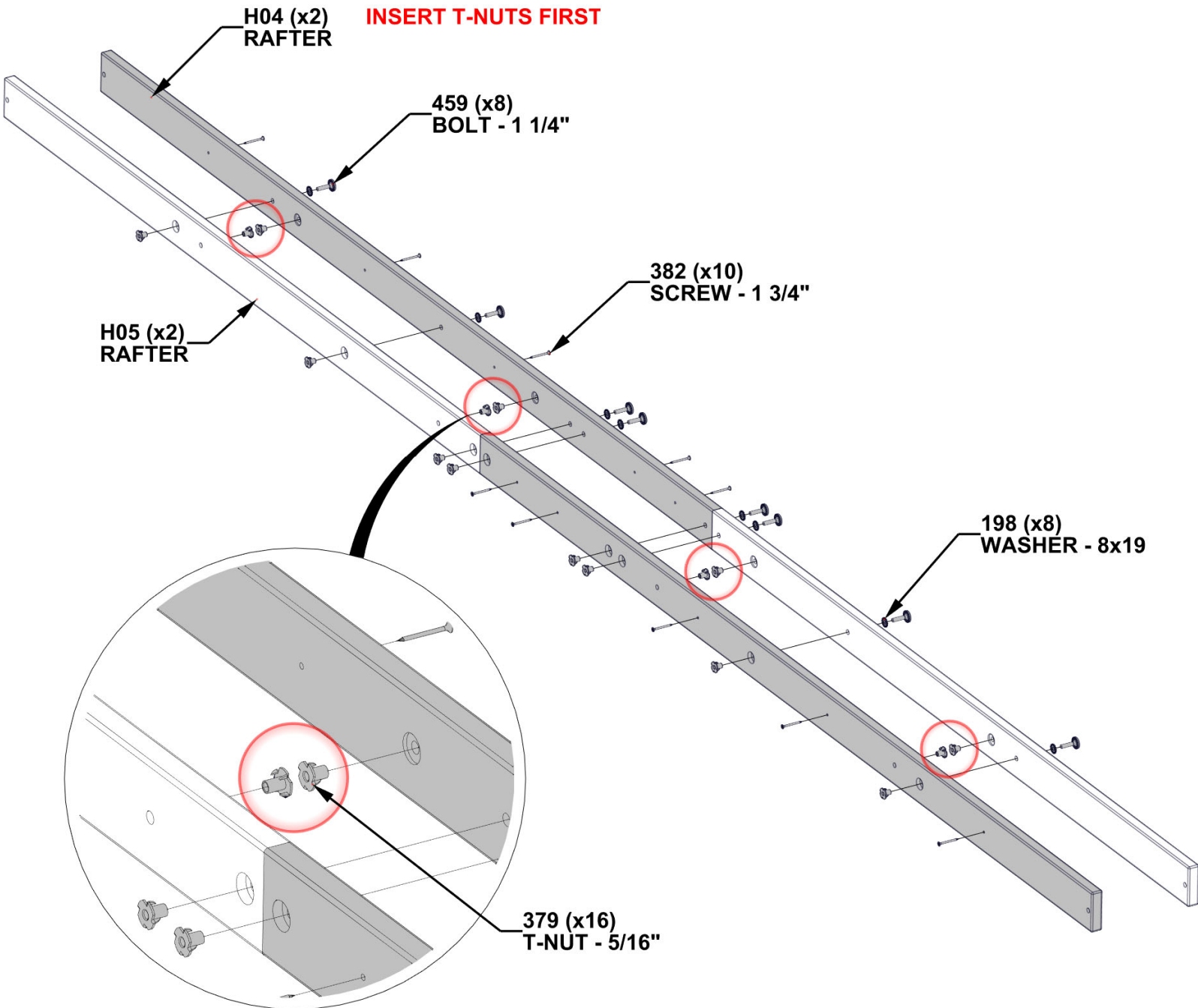

STEP 18 - RAFTER ASSEMBLY

QTY	PART NUMBER	DESCRIPTION
2	H100195	BOLT WH 5/16x2 3/4 BLK
2	H100478	WASHER FLAT 8x27 BLK
2	H100479	NUT LOCK 5/16 BLK

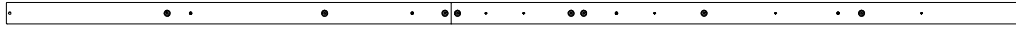

RAFTER ASSEMBLY FROM PREVIOUS STEP

478 (x2)
WASHER - 8x27

479 (x2)
LOCK NUT - 5/16"

195 (x2)
BOLT-2 3/4"

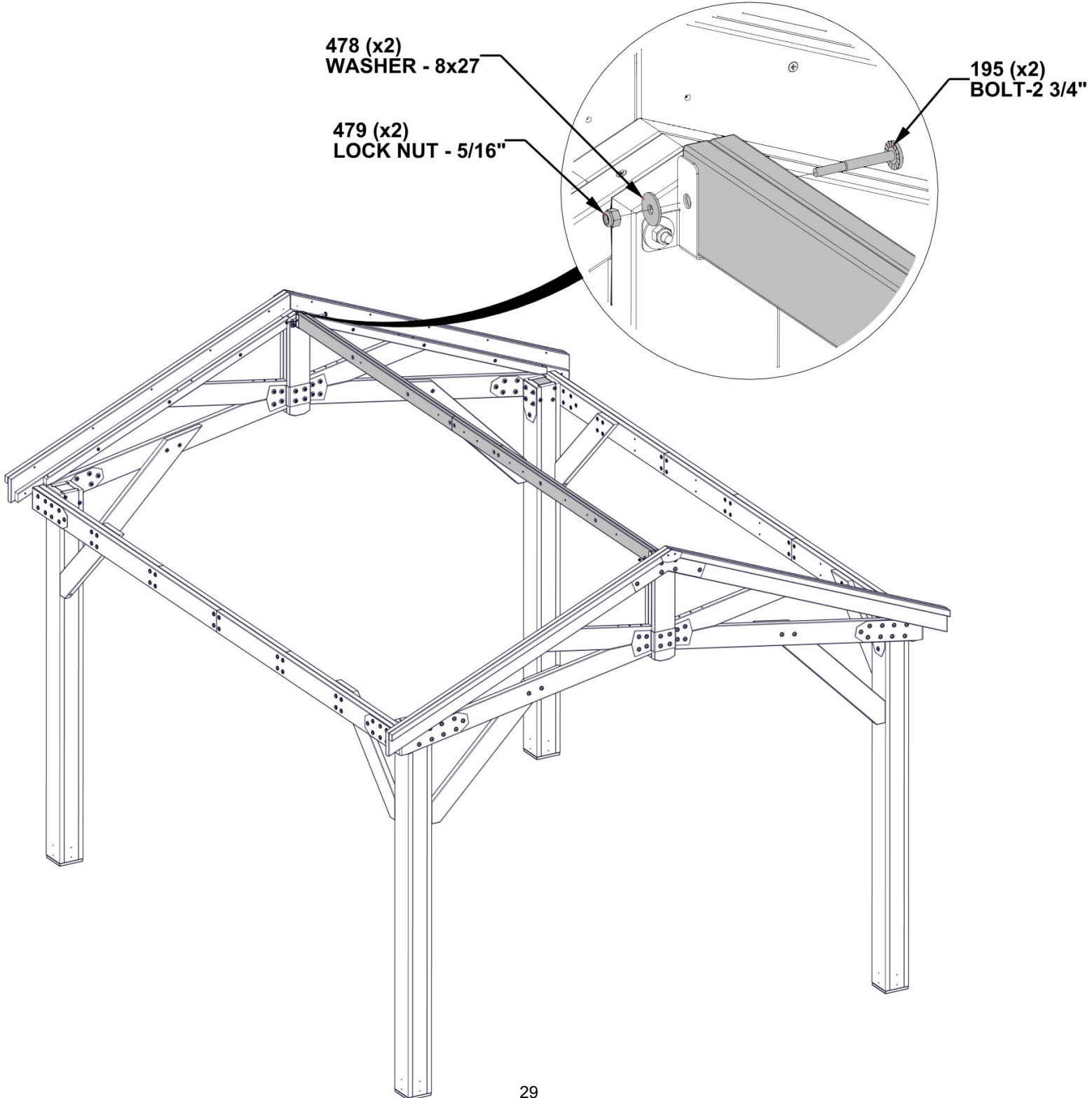

STEP 19 - ROOF PANEL ASSEMBLY

QTY	PART NUMBER	DESCRIPTION
2	H100198	WASHER LOCK EXT 8x19
24	H100391	SCREW PFH 8x2 BLK
2	H100478	WASHER FLAT 8x27 BLK
2	H100479	NUT LOCK 5/16 BLK
2	H100503	BOLT WH 5/16x3 1/2 BLK

H02 | FASCIA - W4L16891
(x1) | 1"x3 3/8"x80 3/8" (24x86x2040)

H03 | FASCIA - W4L16892
(x1) | 1"x3 3/8"x87" (24x86x2209)

H06 | FASCIA - W4L16895
(x1) | 1"x3 3/8"x63 1/2" (24x86x1614)

H07 | FASCIA - W4L16896
(x1) | 1"x3 3/8"x70 1/8" (24x86x1783)

E01 | RAFTER - W4L16858
(x4) | 1 3/8"x3 3/8"x76 3/8" (36x86x1941)

E05 | RAFTER - W4L16862
(x2) | 1 3/8"x3 3/8"x76 3/8" (36x86x1941)

ROOF PANEL A

DO NOT REPEAT THIS STEP FOR SECOND 14FT PANEL. IT IS ASSEMBLED DIFFERENTLY STARTING IN STEP 26.

DIMENSIONS ARE CRITICAL FOR CORRECT ORIENTATION.

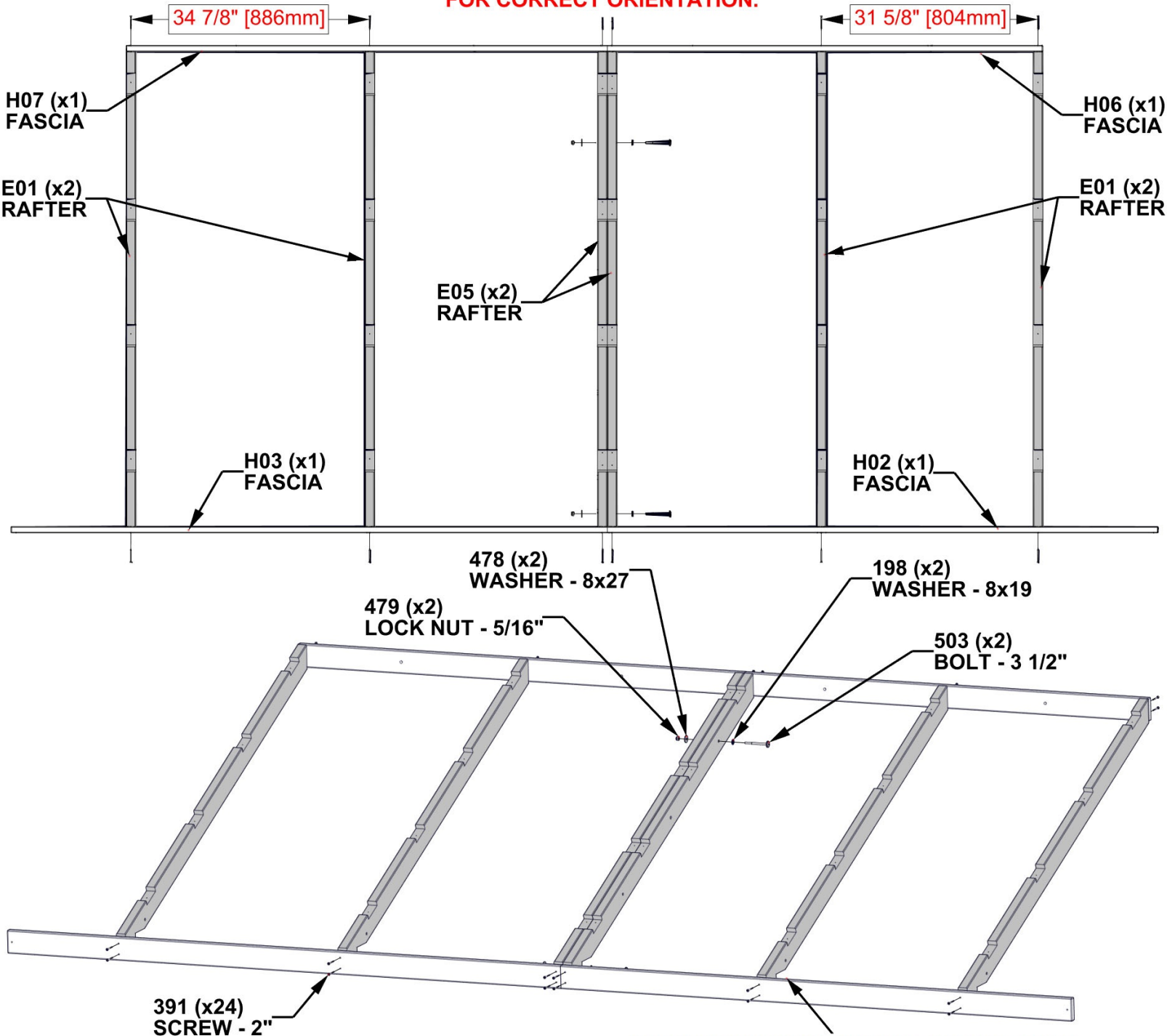

NOTE LOCATION OF HOLES AND NOTCHES.

STEP 20A - ROOF PANEL ASSEMBLY

QTY	PART NUMBER	DESCRIPTION
32	H100391	SCREW PFH 8x2 BLK



E03 | SHEATHING BOARD - W4L16889
(x4) 1 3/8"x3 3/8"x80 3/8" (36x86x2040)



E04 | SHEATHING BOARD - W4L16890
(x4) 1 3/8"x3 3/8"x87" (36x86x2209)

ROOF PANEL A

**E04 (x4)
SHEATHING BOARD**

**E03 (x4)
SHEATHING BOARD**

**391 (x32)
SCREW - 2"**

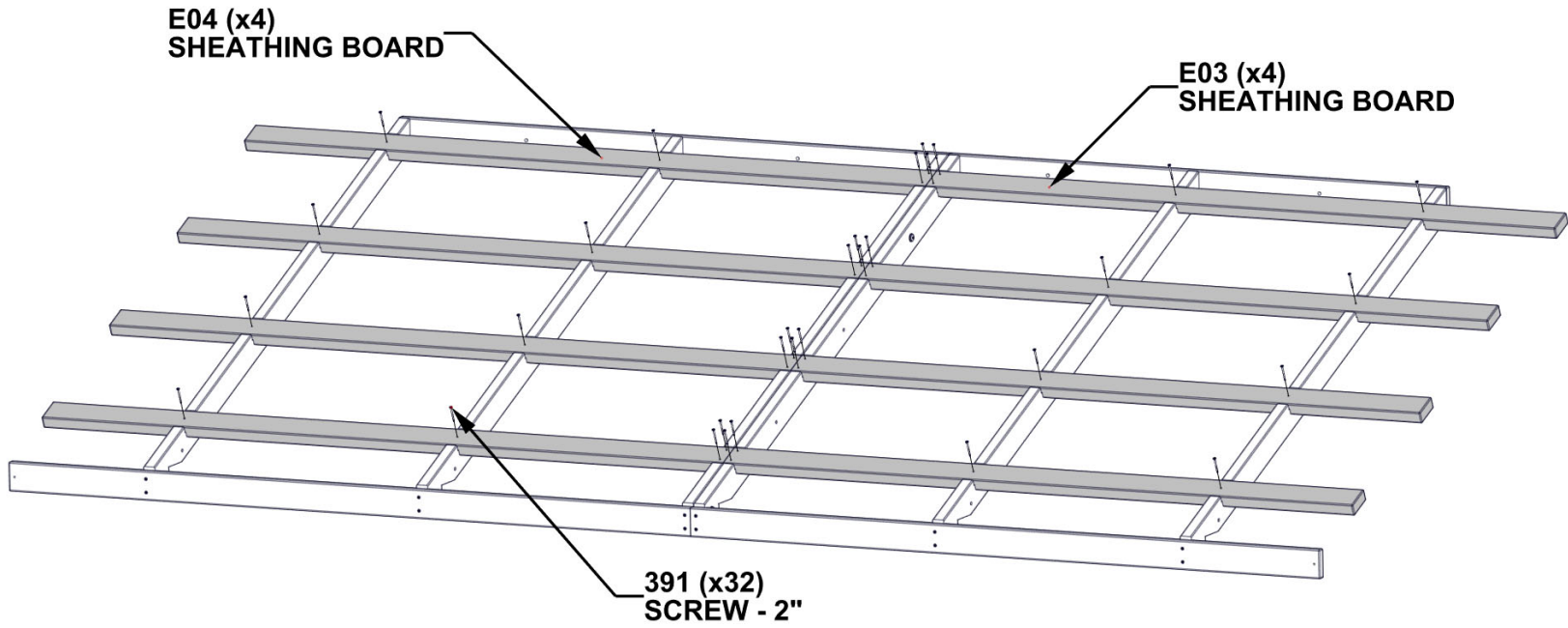

STEP 20B - ROOF PANEL ASSEMBLY

ROOF PANEL A

TIP: LOOSEN HARDWARE TO ADJUST FOR SQUARING IF NEEDED

CRITICAL:

- SQUARE UNIT BEFORE PROCEEDING TO NEXT STEPS.
- THE BELOW DIMENSIONS ARE CRITICAL TO THE FINAL ROOF ASSEMBLY.
- MEASUREMENTS SHOULD BE HELD WITHIN +/- 1/4".
- MEASUREMENTS OUTSIDE OF TOLERANCE WILL LEAD TO THE INABILITY TO ASSEMBLY THE ROOF.

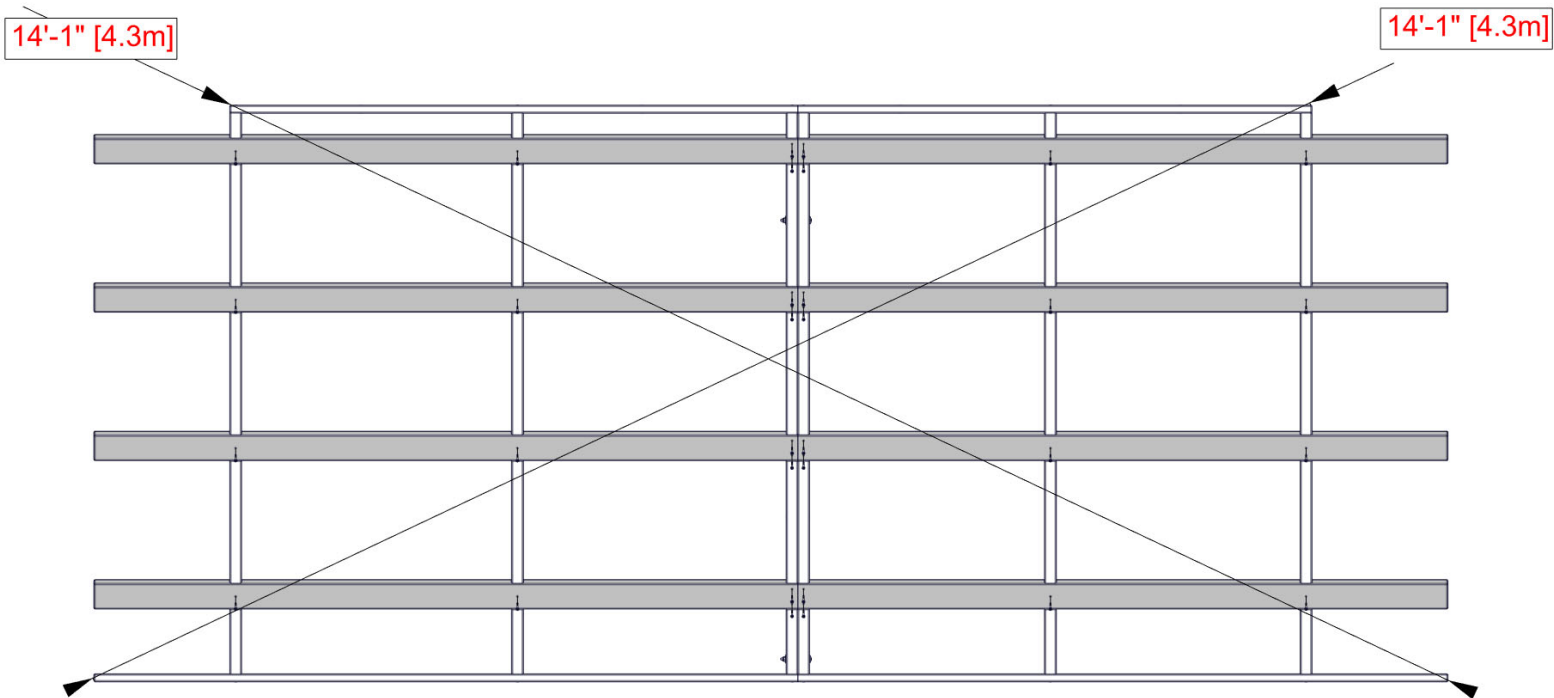

STEP 21 - ROOF PANEL ASSEMBLY

ROOF PANEL A

USE THIS PAGE TO FAMILIARIZE YOURSELF WITH THE ROOF PANEL AND ASSIST YOU IN STEPS 22-24.

TIPS:

- REMOVE PROTECTIVE BLUE FILM
- START AT THE END INDICATED AND ASSEMBLE IN THE DIRECTION OF THE ARROW

GLOVES SHOULD BE WORN WHEN HANDLING ROOF PANELS: EDGES ARE SHARP.

THE PRE-DRILLED HOLES ON EACH PANEL SHOULD ALWAYS BE POSITIONED ON THE RIDGE SIDE.

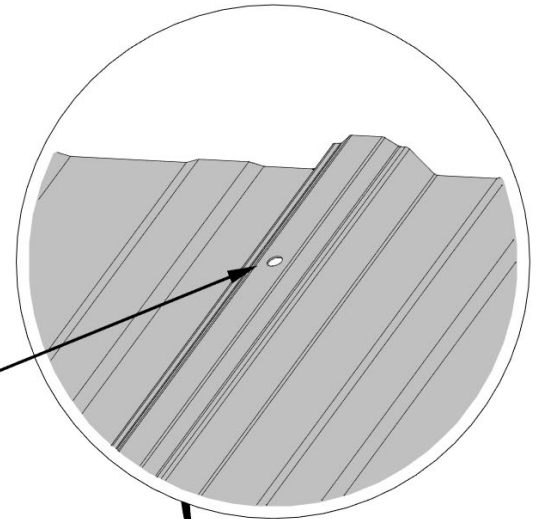

RIDGE

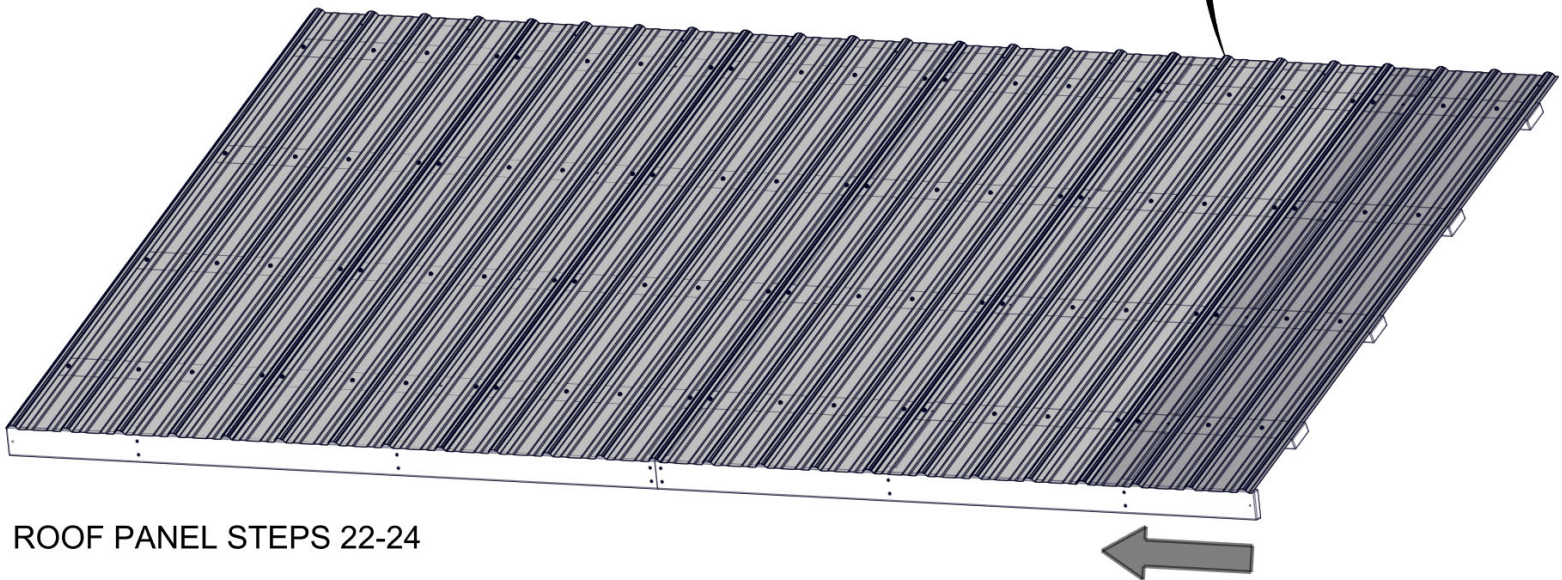

ROOF PANEL STEPS 22-24

STEP 22 - ROOF PANEL ASSEMBLY

QTY	PART NUMBER	DESCRIPTION
28	H100833	SCREW WOODGRIP 10-16x3/4"

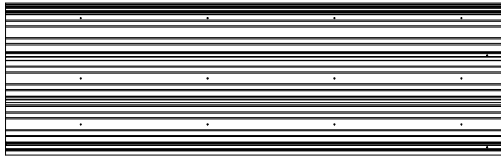

A4M01253 (x1) | 29 GA STEEL SHEETING

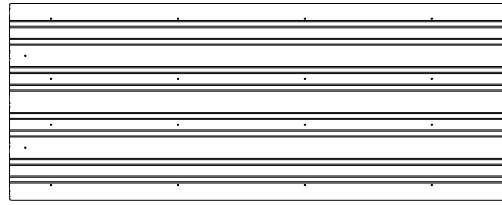

A4M01124 (x1) | 29 GA STEEL SHEETING

ROOF PANEL A

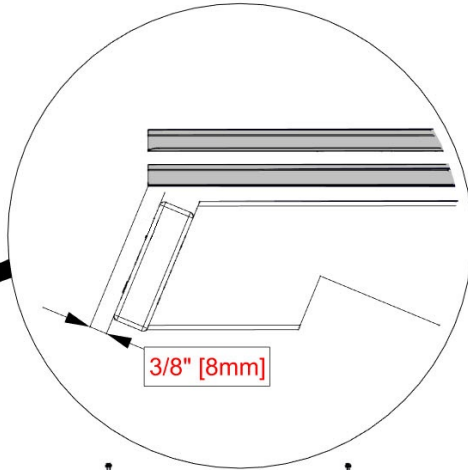

3/8" [8mm]

NOTE RIB OVERLAP

833 (x28)
SCREW - 3/4"

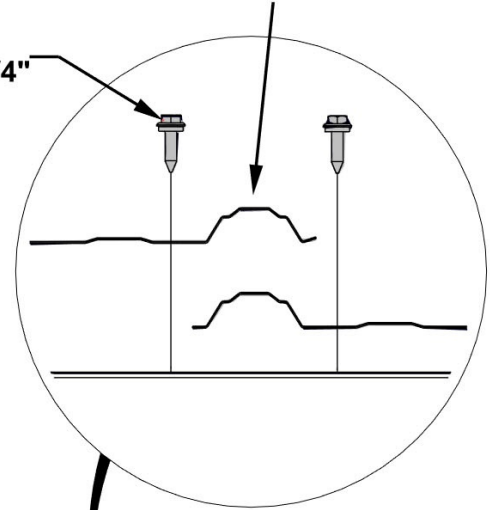

MAKE SURE YOUR ROOF PANEL IS SQUARE BEFORE MOVING ON.

1253 (x1)
29 GA STEEL SHEETING

1124 (x1)
29 GA STEEL SHEETING

HOLD SHEETING INSIDE OF FRAME MEASURING FROM RIB AS SHOWN.

1/2" [12mm]

STEP 23 - ROOF PANEL ASSEMBLY

QTY	PART NUMBER	DESCRIPTION
32	H100833	SCREW WOODGRIP 10-16x3/4"



A4M01715 (x1) | 29 GA STEEL SHEETING

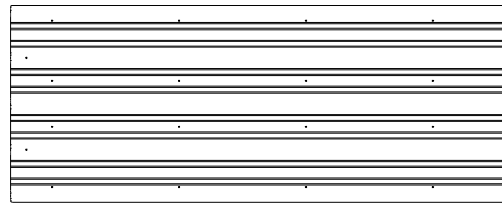

A4M01124 (x1) | 29 GA STEEL SHEETING

ROOF PANEL A

833 (x32)
SCREW - 3/4"

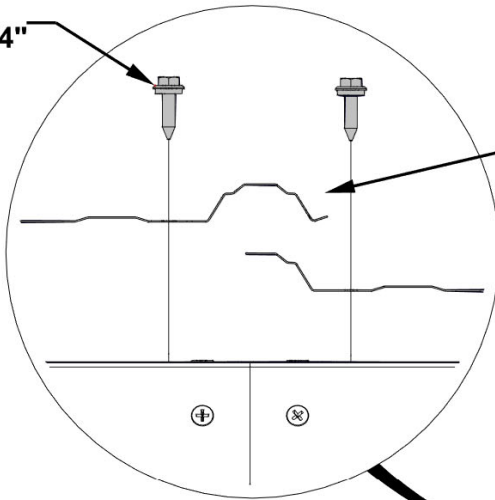

NOTE RIB OVERLAP

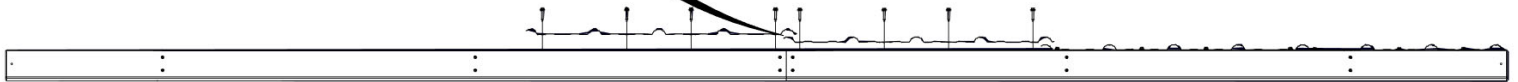

ENSURE CORRECT PLACEMENT OF 1715 STEEL SHEETING.

1715 (x1)
29 GA STEEL SHEETING

1124 (x1)
29 GA STEEL SHEETING

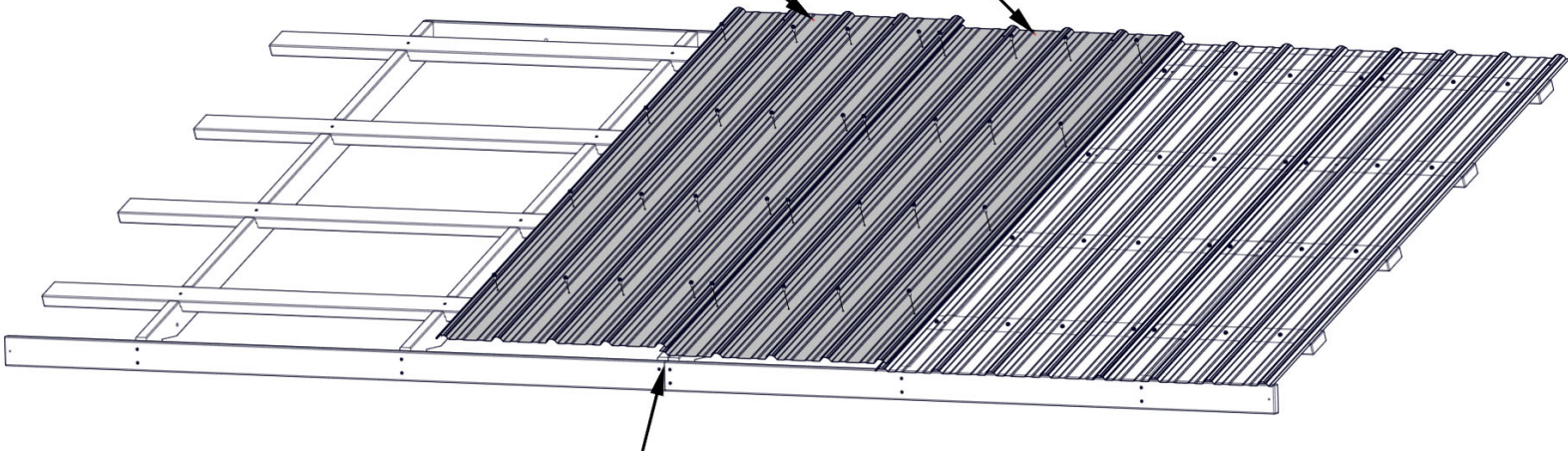

FLUSH ENDS OF ALL SHEETS

STEP 24 - ROOF PANEL ASSEMBLY

QTY	PART NUMBER	DESCRIPTION
32	H100833	SCREW WOODGRIP 10-16x3/4"

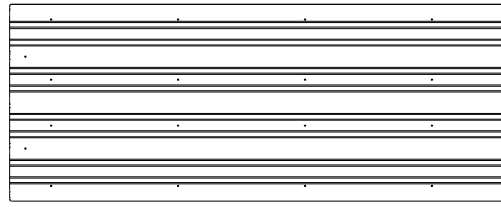

A4M01124 (x2) | 29 GA STEEL SHEETING

ROOF PANEL A

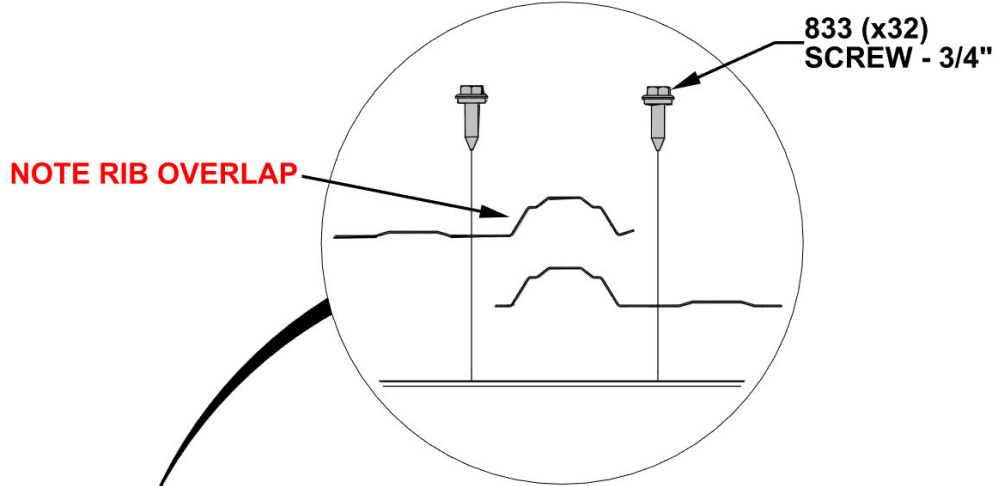

1124 (x2)
29 GA STEEL SHEETING

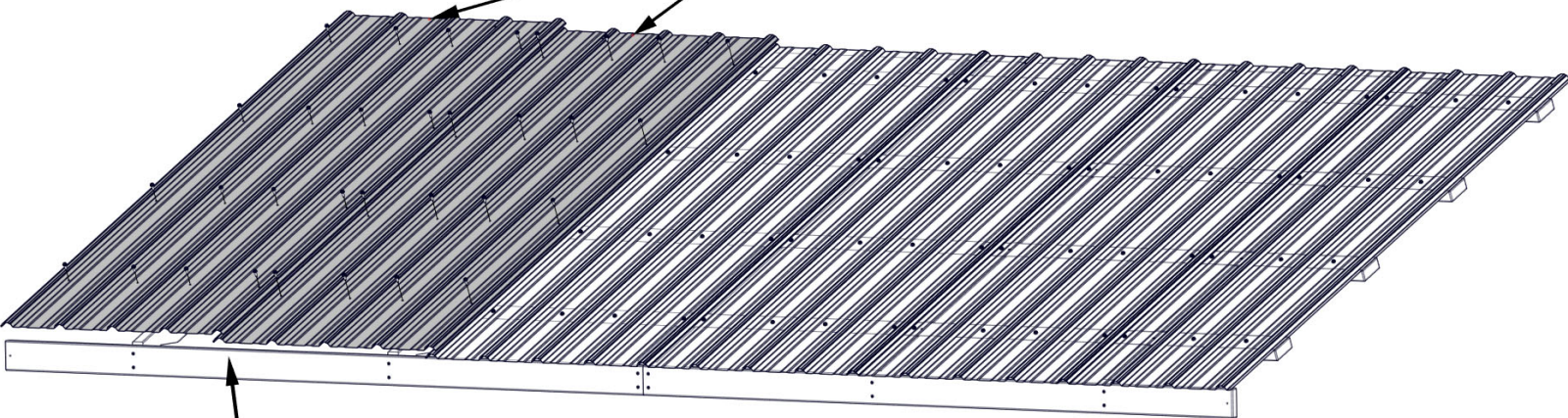

FLUSH ENDS OF ALL SHEETS

STEP 25 - ROOF PANEL ASSEMBLY

ROOF PANEL A

SEPARATE ROOF PANEL AT THIS TIME FOR EASE OF ASSEMBLING.

REMOVE HARDWARE AND SET TO THE SIDE AS IT WILL BE USED AGAIN AFTER BOTH ROOF PANELS ARE INSTALLED.

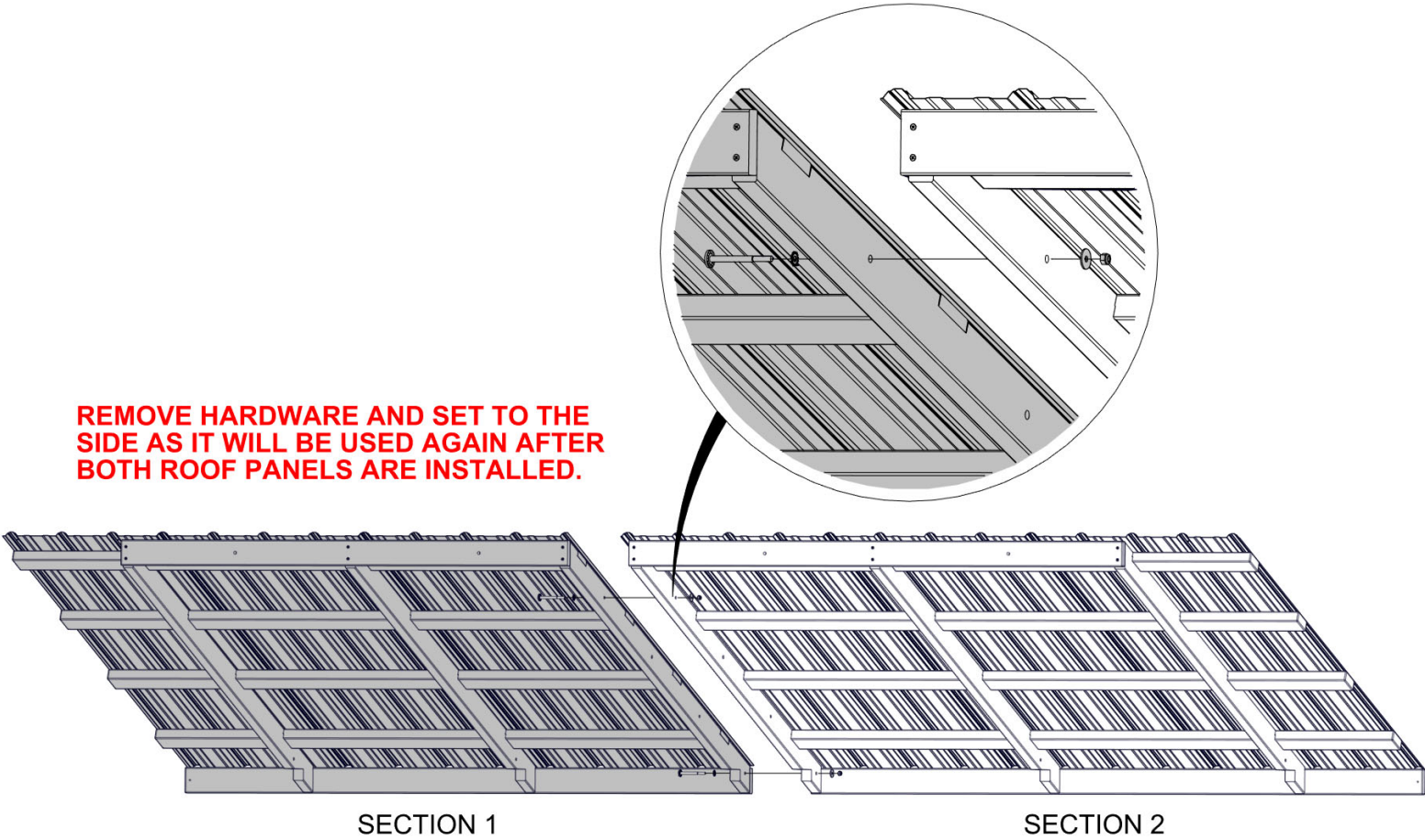

STEP 26 - ROOF PANEL ASSEMBLY

QTY	PART NUMBER	DESCRIPTION
2	H100198	WASHER LOCK EXT 8x19
24	H100391	SCREW PFH 8x2 BLK
2	H100478	WASHER FLAT 8x27 BLK
2	H100479	NUT LOCK 5/16 BLK
2	H100503	BOLT WH 5/16x3 1/2 BLK

H02 FASCIA - W4L16891
(x1) 1"x3 3/8"x80 3/8" (24x86x2040)

H03 FASCIA - W4L16892
(x1) 1"x3 3/8"x87" (24x86x2209)

H06 FASCIA - W4L16895
(x1) 1"x3 3/8"x63 1/2" (24x86x1614)

H07 FASCIA - W4L16896
(x1) 1"x3 3/8"x70 1/8" (24x86x1783)

E01 RAFTER - W4L16858
(x4) 1 3/8"x3 3/8"x76 3/8" (36x86x1941)

E05 RAFTER - W4L16862
(x2) 1 3/8"x3 3/8"x76 3/8" (36x86x1941)

ROOF PANEL B

DIMENSIONS ARE CRITICAL FOR CORRECT ORIENTATION.

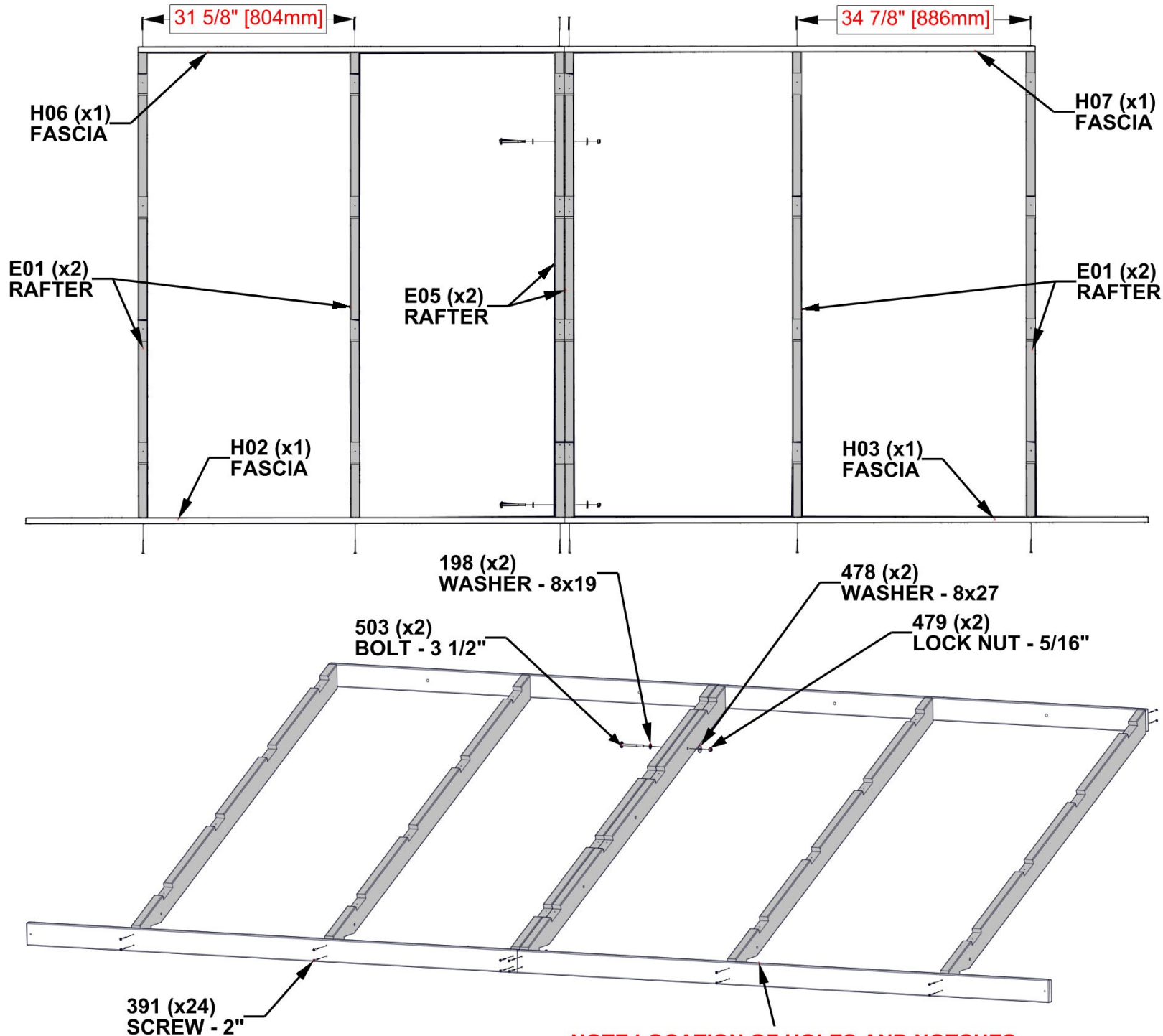

NOTE LOCATION OF HOLES AND NOTCHES.

STEP 27A - ROOF PANEL ASSEMBLY

QTY	PART NUMBER	DESCRIPTION
32	H100391	SCREW PFH 8x2 BLK

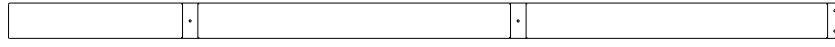

E03 | SHEATHING BOARD - W4L16889
(x4) | 1 3/8"x3 3/8"x80 3/8" (36x86x2040)



E04 | SHEATHING BOARD - W4L16890
(x4) | 1 3/8"x3 3/8"x87" (36x86x2209)

ROOF PANEL B

E03 (x4)
SHEATHING BOARD

E04 (x4)
SHEATHING BOARD

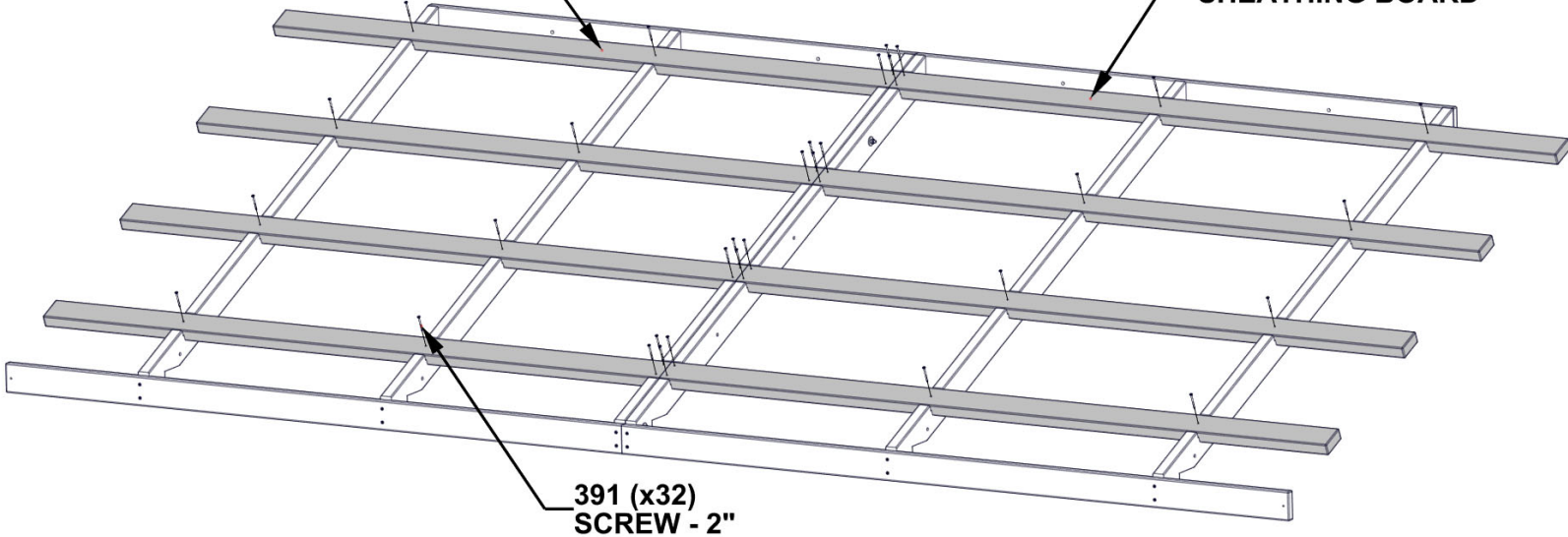

391 (x32)
SCREW - 2"

STEP 27B - ROOF PANEL ASSEMBLY

ROOF PANEL B

TIP: LOOSEN HARDWARE TO ADJUST FOR SQUARING IF NEEDED

CRITICAL:

- SQUARE UNIT BEFORE PROCEEDING TO NEXT STEPS.
- THE BELOW DIMENSIONS ARE CRITICAL TO THE FINAL ROOF ASSEMBLY.
- MEASUREMENTS SHOULD BE HELD WITHIN +/- 1/4".
- MEASUREMENTS OUTSIDE OF TOLERANCE WILL LEAD TO THE INABILITY TO ASSEMBLY THE ROOF.

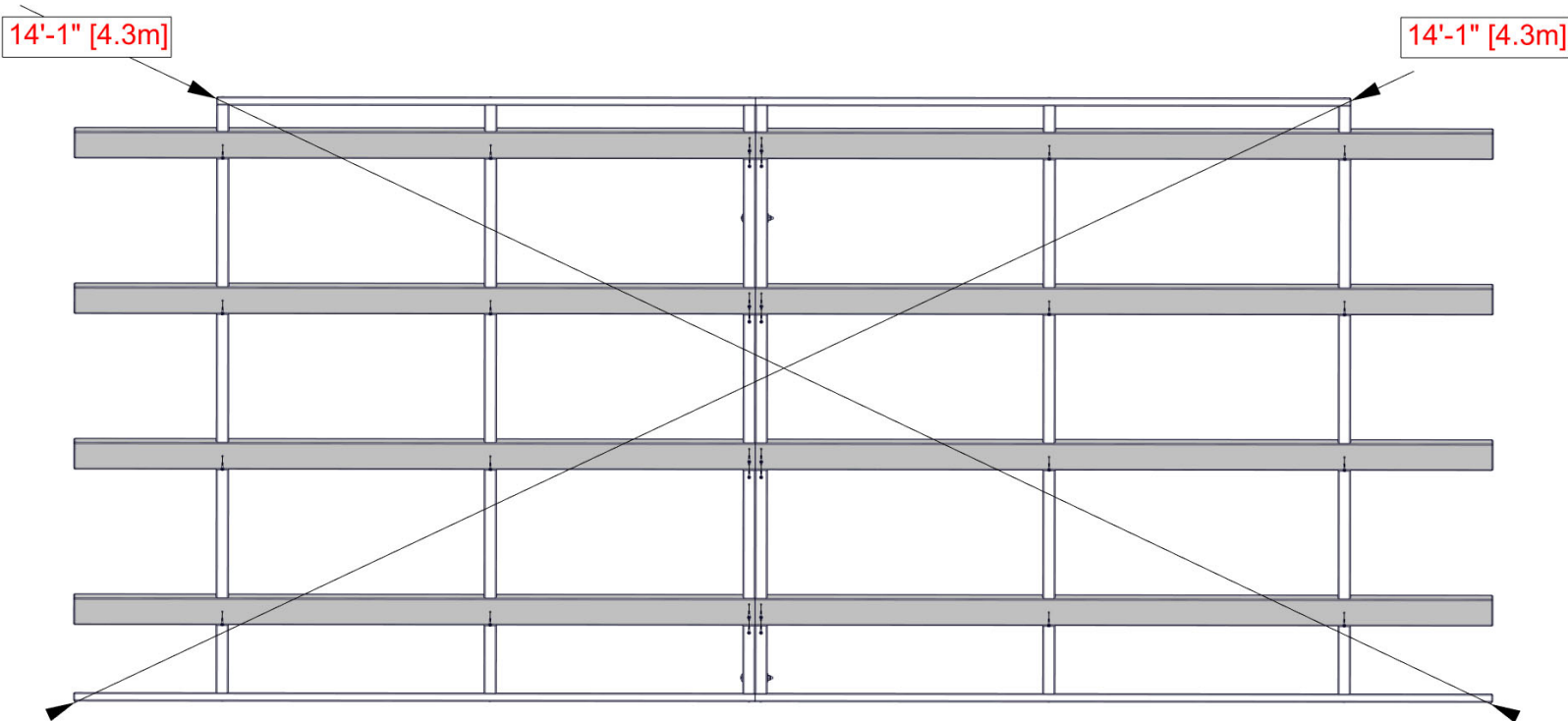

STEP 28 - ROOF PANEL ASSEMBLY

ROOF PANEL B

USE THIS PAGE TO FAMILIARIZE YOURSELF WITH THE ROOF PANEL AND ASSIST YOU IN STEPS 29-31.

TIPS:

- REMOVE PROTECTIVE BLUE FILM
- START AT THE END INDICATED AND ASSEMBLE IN THE DIRECTION OF THE ARROW

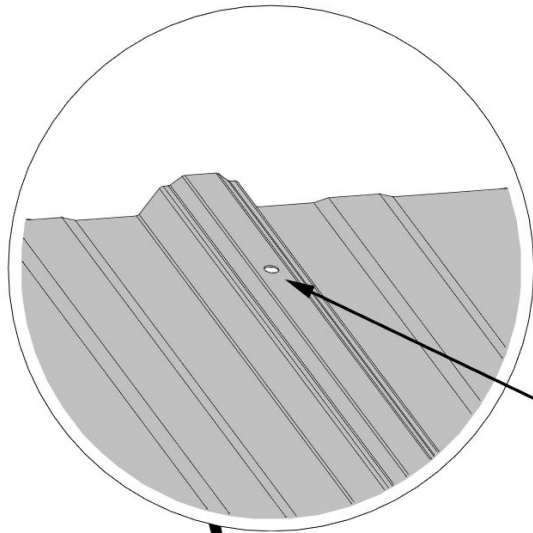

GLOVES SHOULD BE WORN WHEN HANDLING ROOF PANELS: EDGES ARE SHARP.

THE PRE-DRILLED HOLES ON EACH PANEL SHOULD ALWAYS BE POSITIONED ON THE RIDGE SIDE.

RIDGE

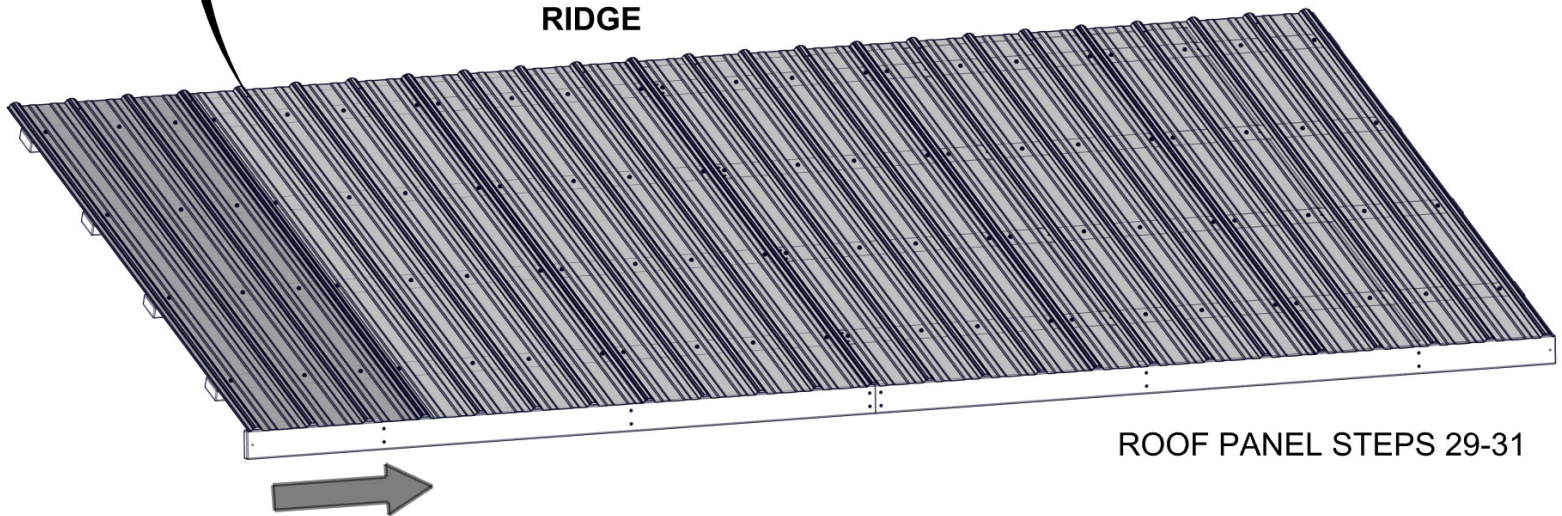

ROOF PANEL STEPS 29-31

STEP 29 - ROOF PANEL ASSEMBLY

QTY	PART NUMBER	DESCRIPTION
28	H100833	SCREW WOODGRIP 10-16x3/4"

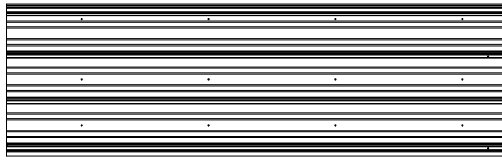

A4M01253 (x1) | 29 GA STEEL SHEETING

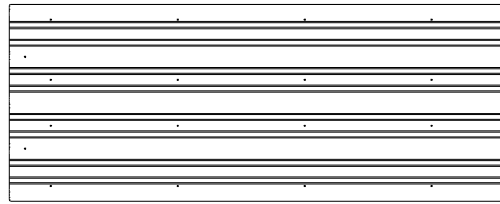

A4M01124 (x1) | 29 GA STEEL SHEETING

ROOF PANEL B

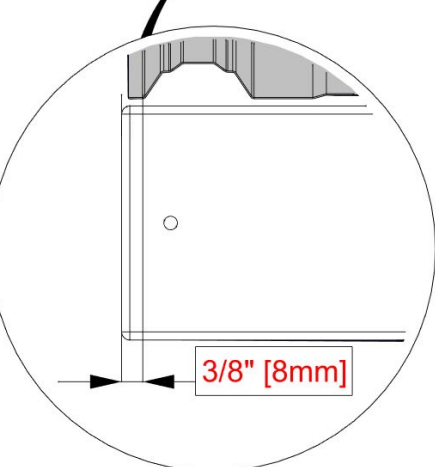
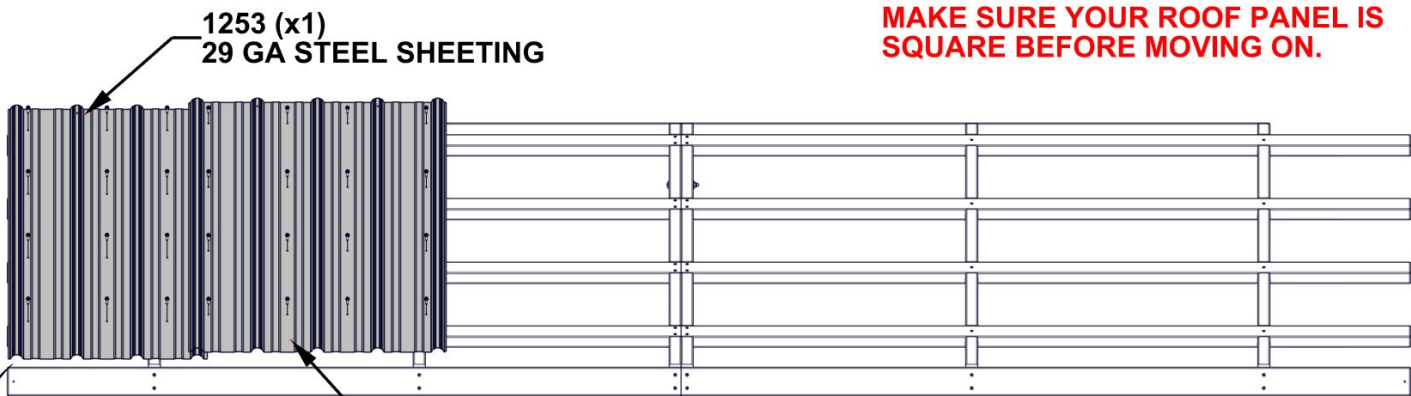
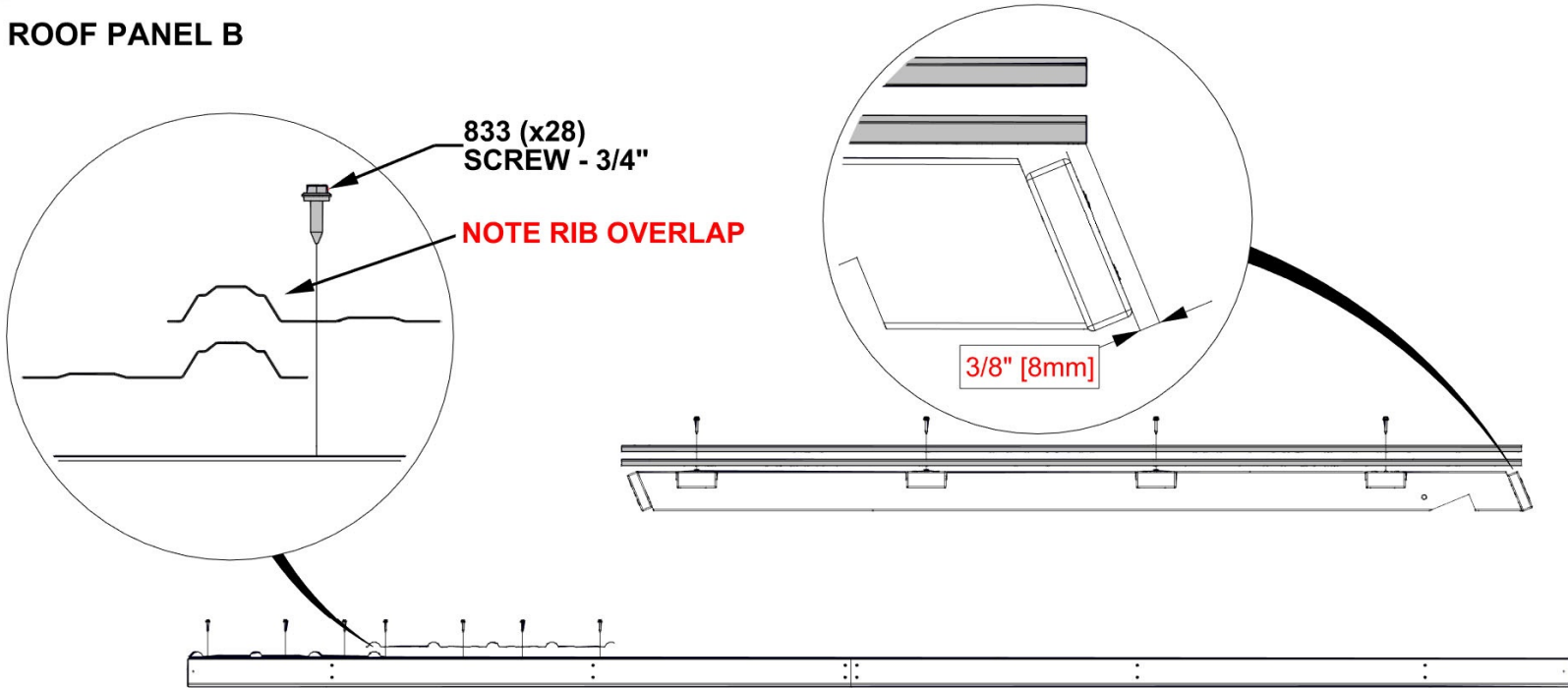

HOLD SHEETING INSIDE OF FRAME MEASURING FROM RIB AS SHOWN.

STEP 30 - ROOF PANEL ASSEMBLY

QTY	PART NUMBER	DESCRIPTION
32	H100833	SCREW WOODGRIP 10-16x3/4"

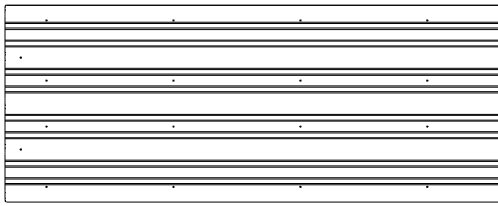

A4M01718 (x1) | 29 GA STEEL SHEETING

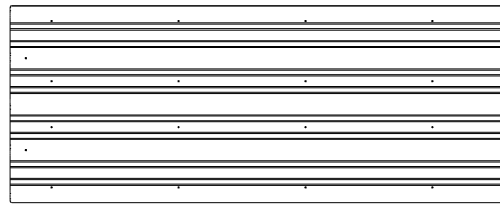

A4M01124 (x1) | 29 GA STEEL SHEETING

ROOF PANEL B

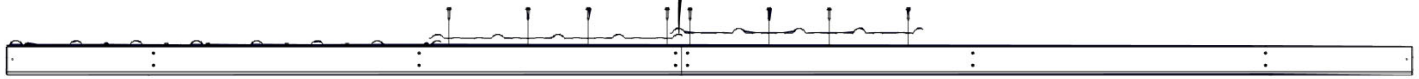
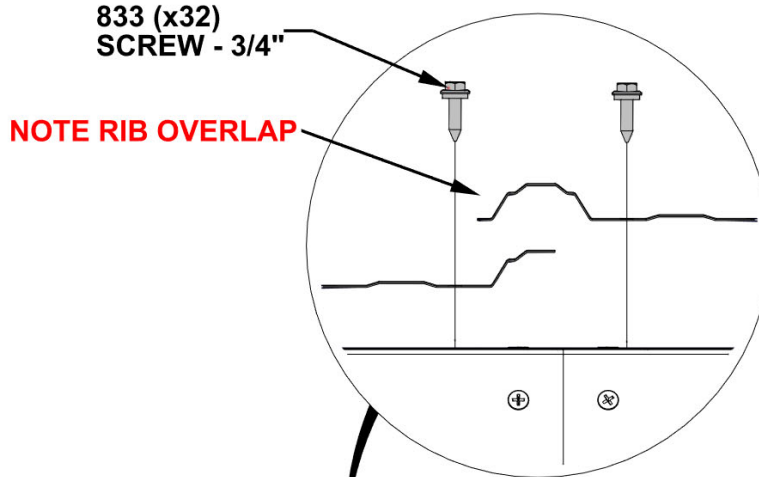

ENSURE CORRECT PLACEMENT OF 1718 STEEL SHEETING.

1124 (x1)
29 GA STEEL SHEETING

1718 (x1)
29 GA STEEL SHEETING

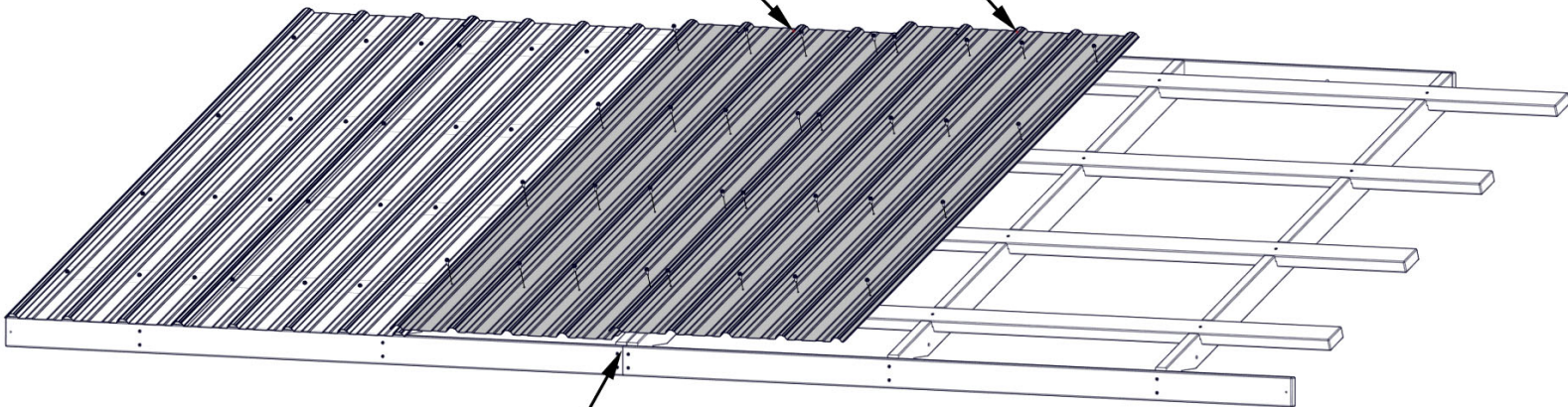

FLUSH ENDS OF ALL SHEETS

STEP 31 - ROOF PANEL ASSEMBLY

QTY	PART NUMBER	DESCRIPTION
32	H100833	SCREW WOODGRIP 10-16x3/4"

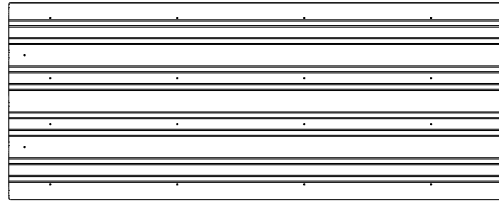

A4M01124 (x2) | 29 GA STEEL SHEETING

ROOF PANEL B

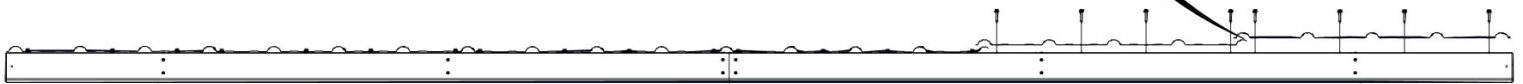
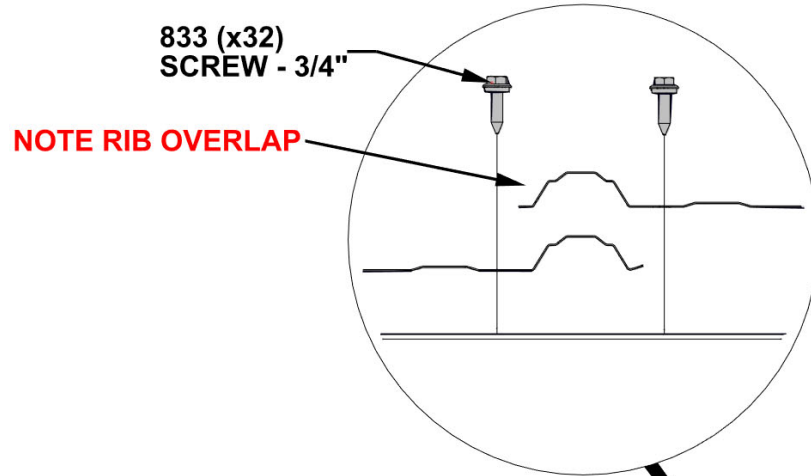

1124 (x2)
29 GA STEEL SHEETING

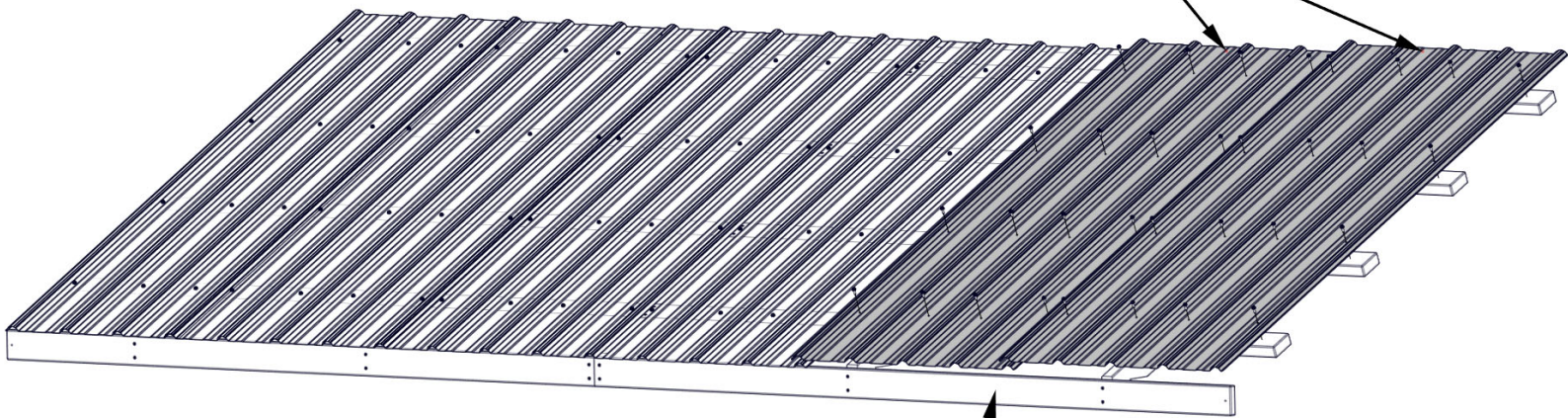

FLUSH ENDS OF ALL SHEETS

STEP 32 - ROOF PANEL ASSEMBLY

ROOF PANEL B

SEPARATE ROOF PANEL AT THIS TIME FOR EASE OF ASSEMBLING.

REMOVE HARDWARE AND SET TO THE SIDE AS IT WILL BE USED AGAIN AFTER BOTH ROOF PANELS ARE INSTALLED.

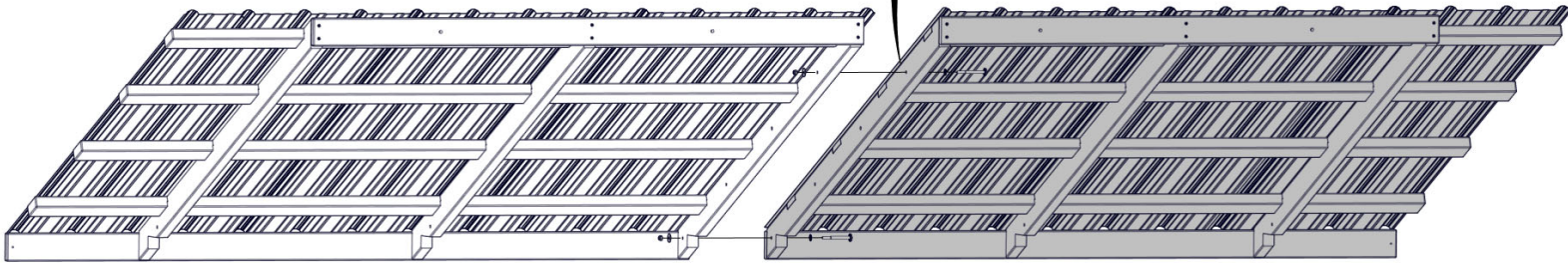
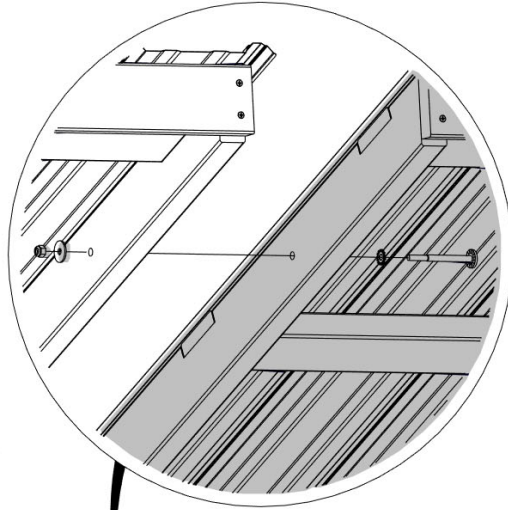

SECTION 2

SECTION 1

STEP 33 - ROOF ASSEMBLY

QTY	PART NUMBER	DESCRIPTION
2	H100198	WASHER LOCK EXT 8x19
2	H100378	BOLT WH 5/16x1 3/4 BLK
1	H100391	SCREW PFH 8x2 BLK

INSTALL ROOF PANEL A, SECTION 1

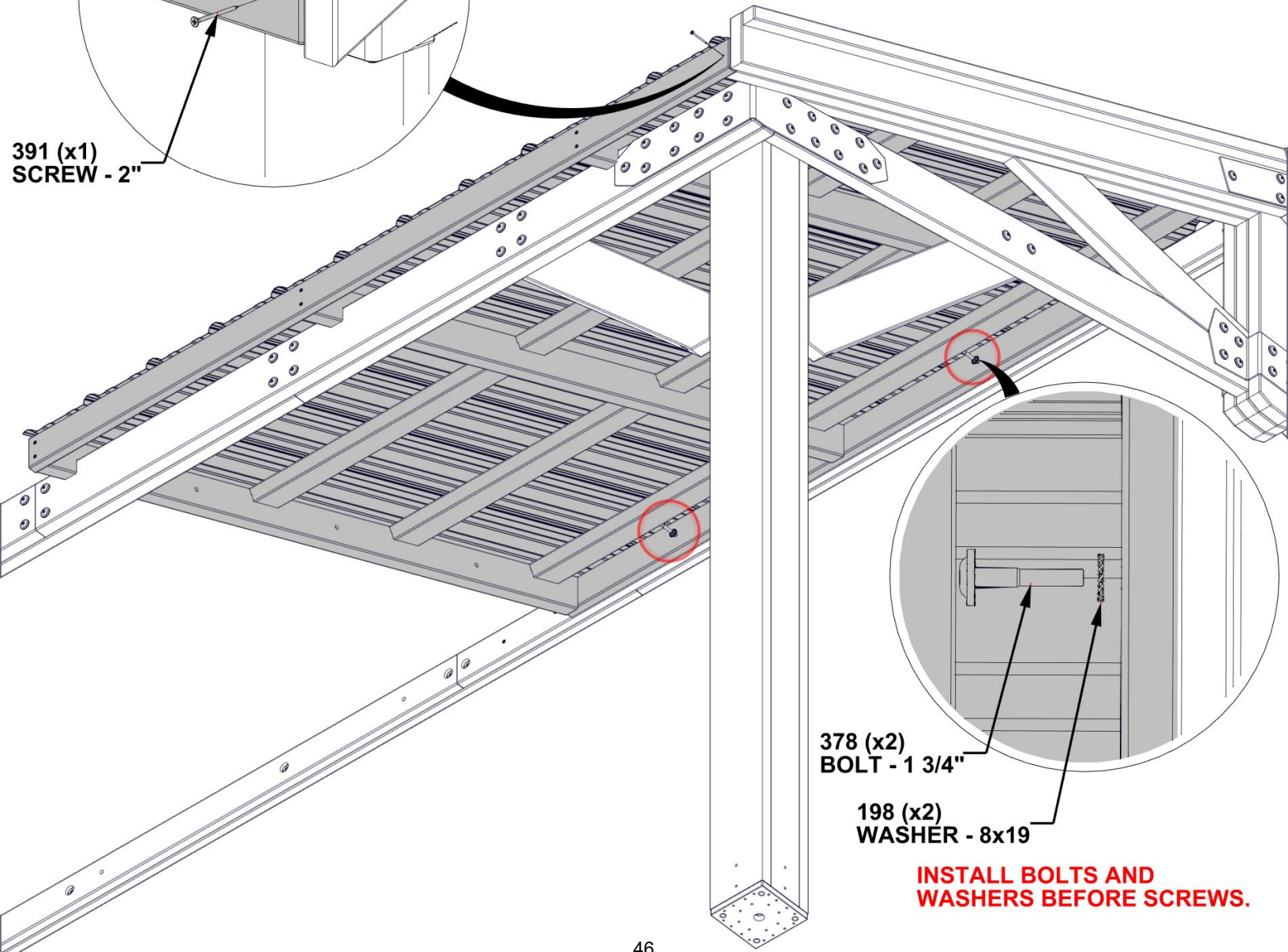
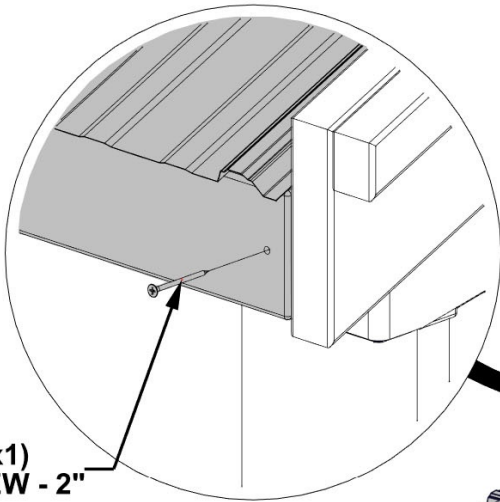
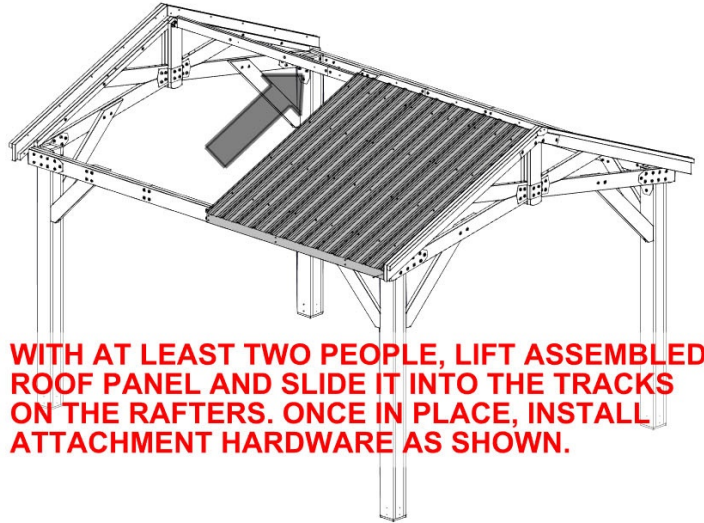

STEP 34 - ROOF ASSEMBLY

QTY	PART NUMBER	DESCRIPTION
2	H100198	WASHER LOCK EXT 8x19
2	H100378	BOLT WH 5/16x1 3/4 BLK
1	H100391	SCREW PFH 8x2 BLK

INSTALL ROOF PANEL B, SECTION 1

INSTALL BOLTS AND WASHERS BEFORE SCREWS.

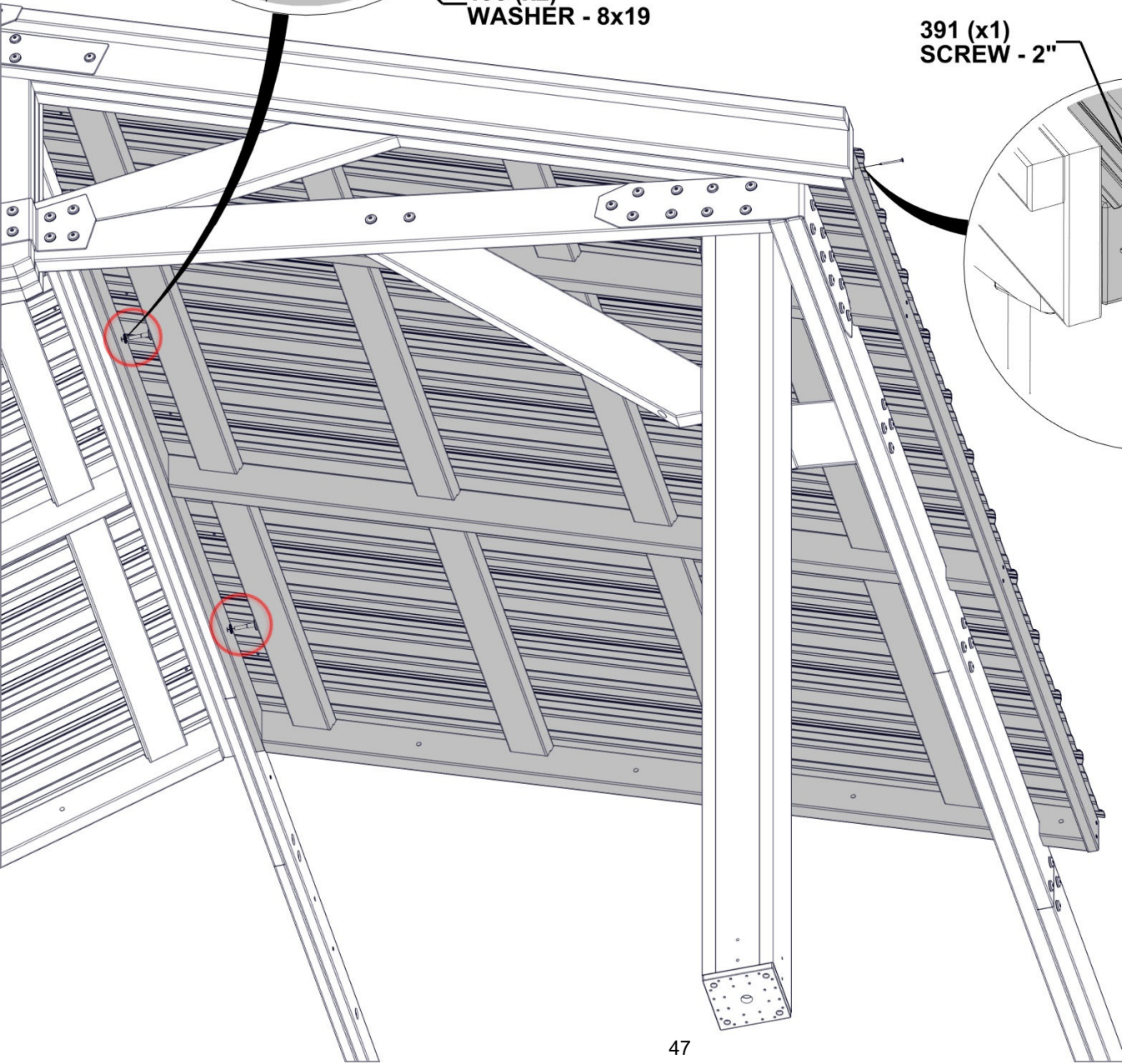
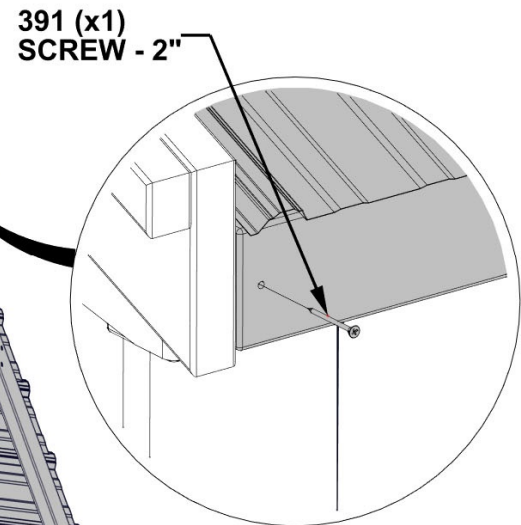
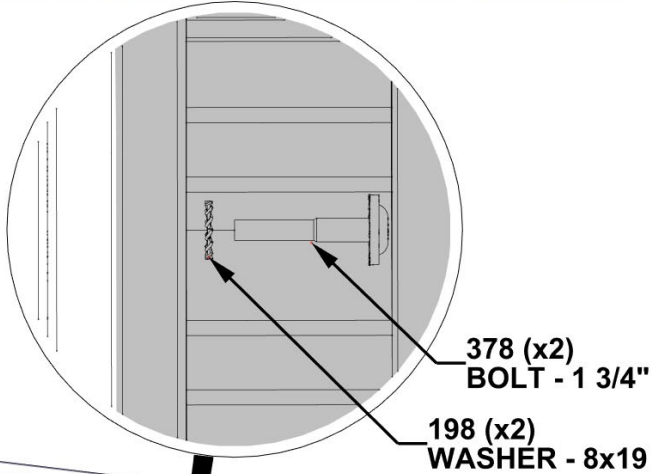
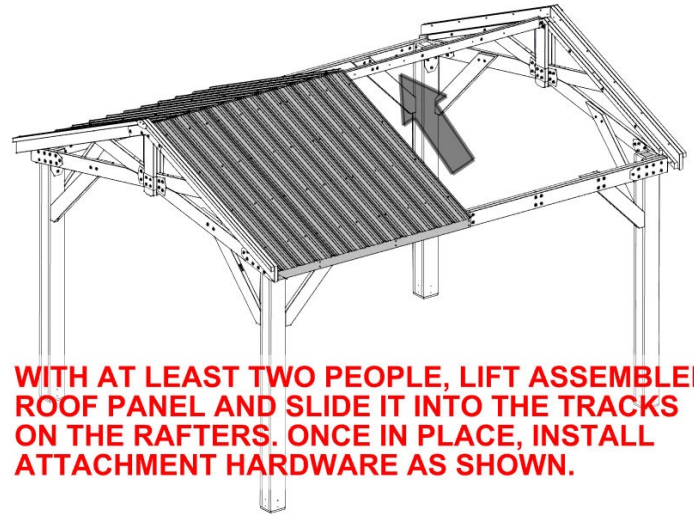

STEP 35 - ROOF ASSEMBLY

QTY	PART NUMBER	DESCRIPTION
5	H100198	WASHER LOCK EXT 8x19
2	H100378	BOLT WH 5/16x1 3/4 BLK
1	H100391	SCREW PFH 8x2 BLK
3	H100478	WASHER FLAT 8x27 BLK
3	H100479	NUT LOCK 5/16 BLK
3	H100503	BOLT WH 5/16x3 1/2 BLK

INSTALL ROOF PANEL A, SECTION 2

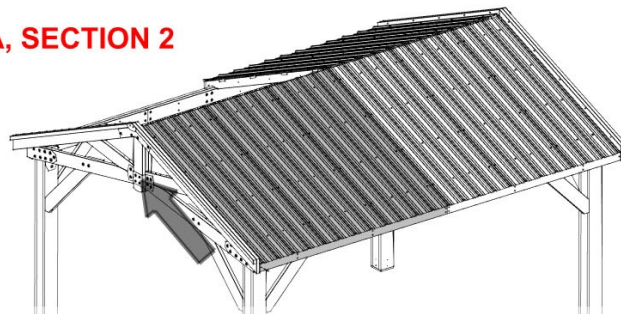

INSTALL BOLTS AND WASHERS BEFORE SCREWS.

198 (x5)
WASHER - 8x19

378 (x2)
BOLT - 1 3/4"

WITH AT LEAST TWO PEOPLE, LIFT ASSEMBLED ROOF PANEL AND SLIDE IT INTO THE TRACKS ON THE RAFTERS. YOU MAY HAVE TO LIFT THE CORNER OF THE EXISTING ROOF PANEL TO GET IT STARTED. ONCE IN PLACE, INSTALL ATTACHMENT HARDWARE AS SHOWN.

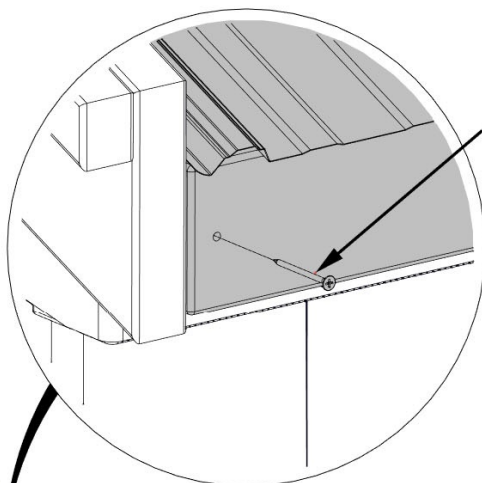
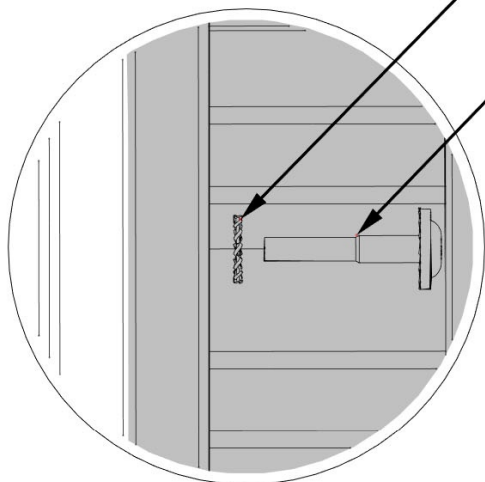

391 (x1)
SCREW - 2"

479 (x3)
LOCK NUT - 5/16"

478 (x3)
WASHER - 8x27

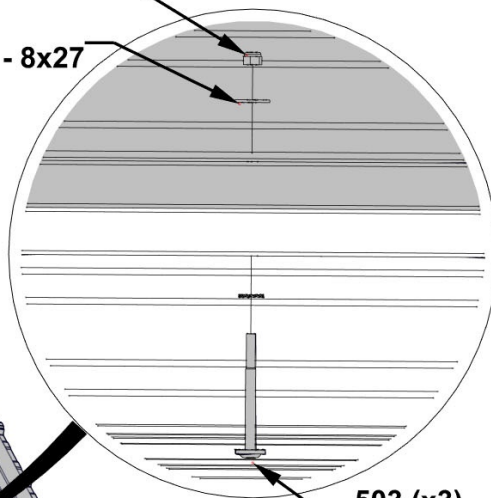

503 (x3)
BOLT - 3 1/2"

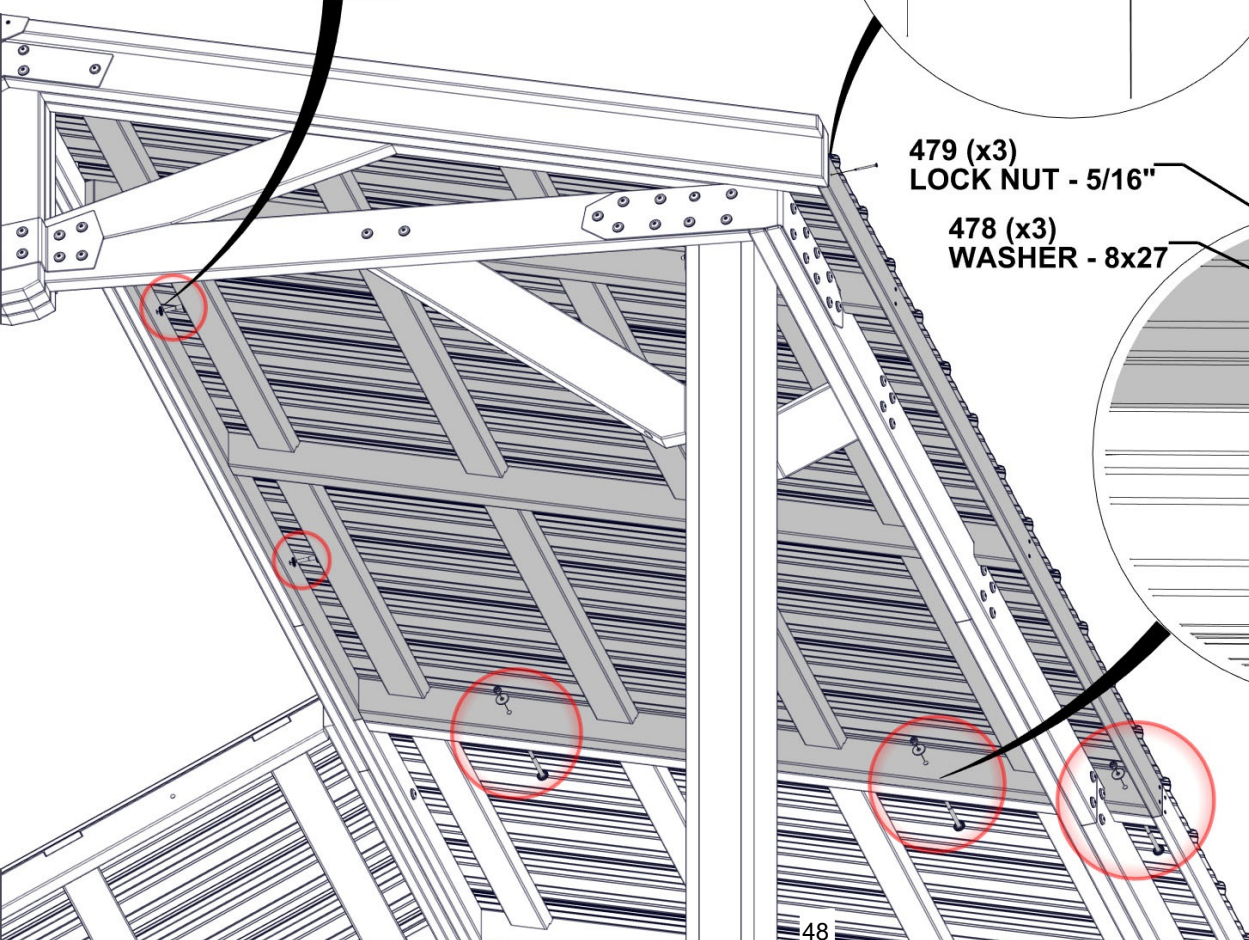

STEP 36 - ROOF ASSEMBLY

QTY	PART NUMBER	DESCRIPTION
5	H100198	WASHER LOCK EXT 8x19
2	H100378	BOLT WH 5/16x1 3/4 BLK
1	H100391	SCREW PFH 8x2 BLK
3	H100478	WASHER FLAT 8x27 BLK
3	H100479	NUT LOCK 5/16 BLK
3	H100503	BOLT WH 5/16x3 1/2 BLK

INSTALL ROOF PANEL B, SECTION 2

WITH AT LEAST TWO PEOPLE, LIFT ASSEMBLED ROOF PANEL AND SLIDE IT INTO THE TRACKS ON THE RAFTERS. YOU MAY HAVE TO LIFT THE CORNER OF THE EXISTING ROOF PANEL TO GET IT STARTED. ONCE IN PLACE, INSTALL ATTACHMENT HARDWARE AS SHOWN.

INSTALL BOLTS AND WASHERS BEFORE SCREWS.

378 (x2)
BOLT - 1 3/4"

198 (x5)
WASHER - 8x19

391 (x1)
SCREW - 2"

479 (x3)
LOCK NUT - 5/16"

478 (x3)
WASHER - 8x27

503 (x3)
BOLT - 3 1/2"

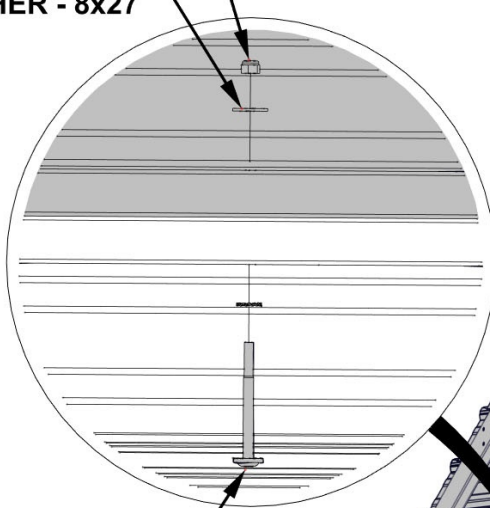
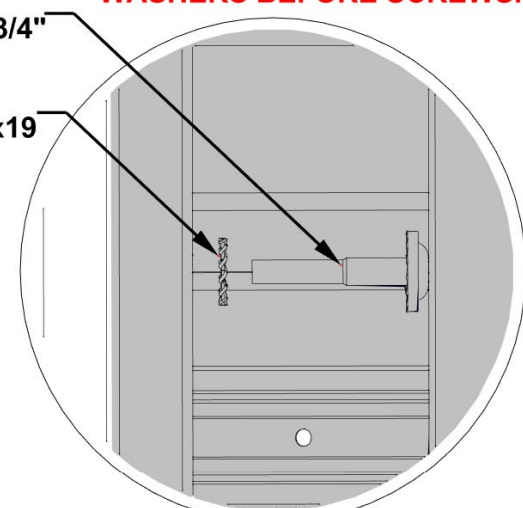
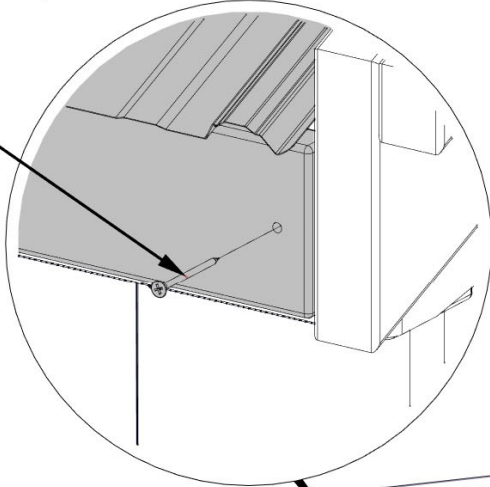
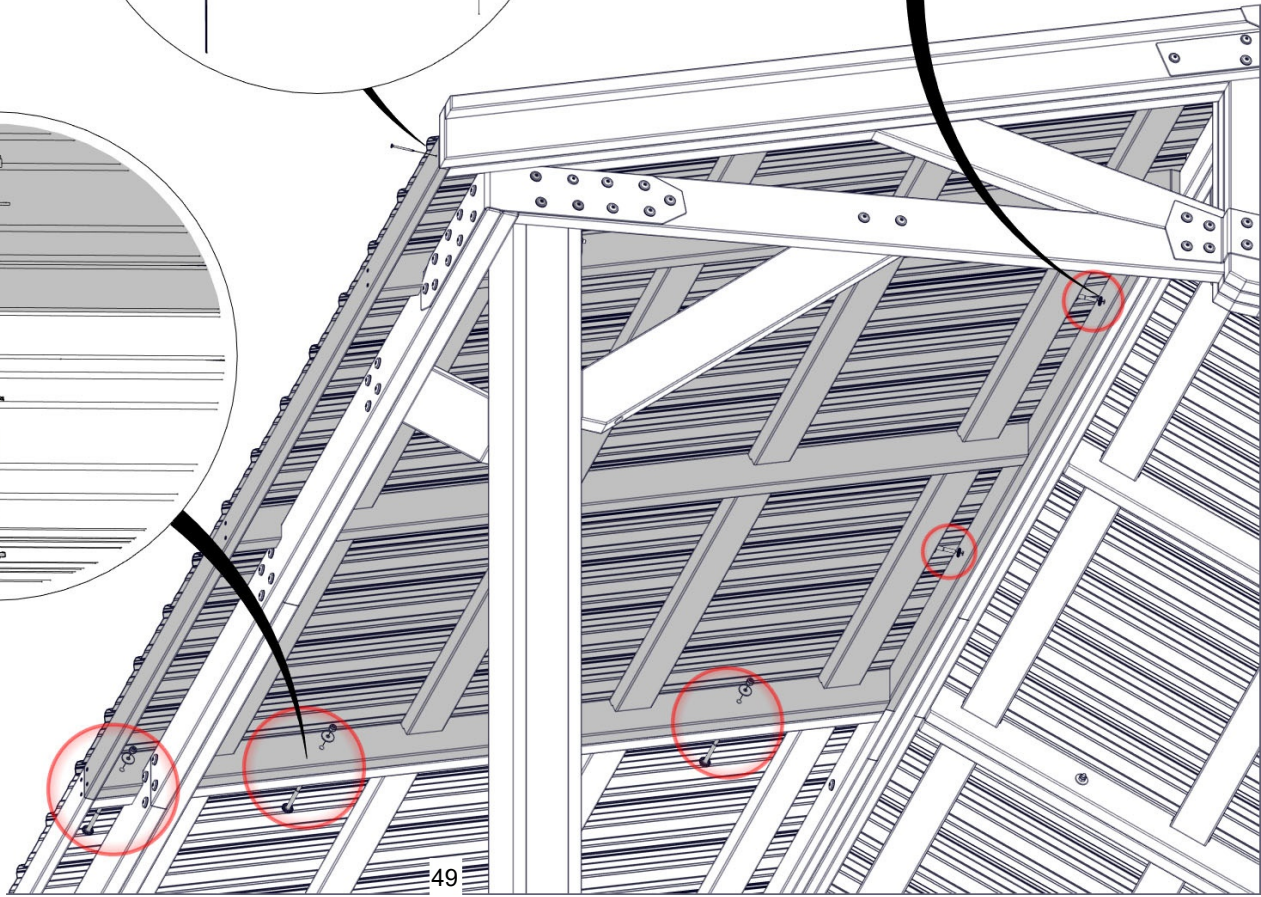

STEP 37 - ROOF ASSEMBLY

QTY	PART NUMBER	DESCRIPTION
2	H100198	WASHER LOCK EXT 8x19
2	H100478	WASHER FLAT 8x27 BLK
2	H100479	NUT LOCK 5/16 BLK
2	H100976	BOLT WH 5/16x6 1/4 BLK



E06 | ACCESSORY TRUSS - W4L16863
 (x2) 1 3/8"x3 3/8"x73 13/16" (36x86x1875)

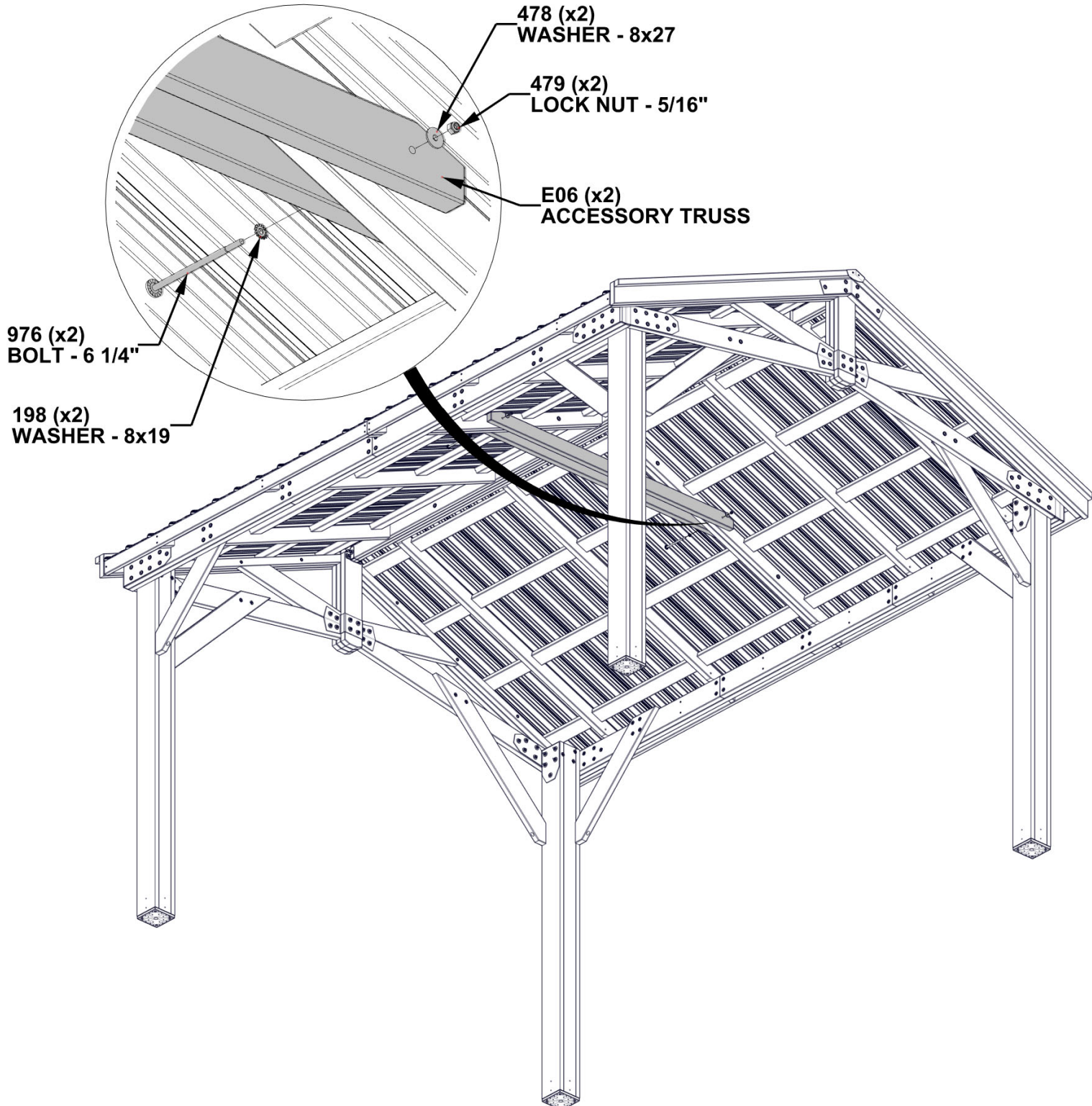

STEP 38 - ROOF ASSEMBLY

QTY	PART NUMBER	DESCRIPTION
8	H100488	BOLT WH 1/4x2 BLK
8	H100630	WASHER FLAT 8x19 BLK
8	H100653	NUT LOCK 1/4 BLK
16	H100823	SCREW PWH 8x1 1/2 BLK

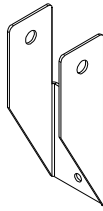

A4M01228
(x8) **RAFTER BRACKET**

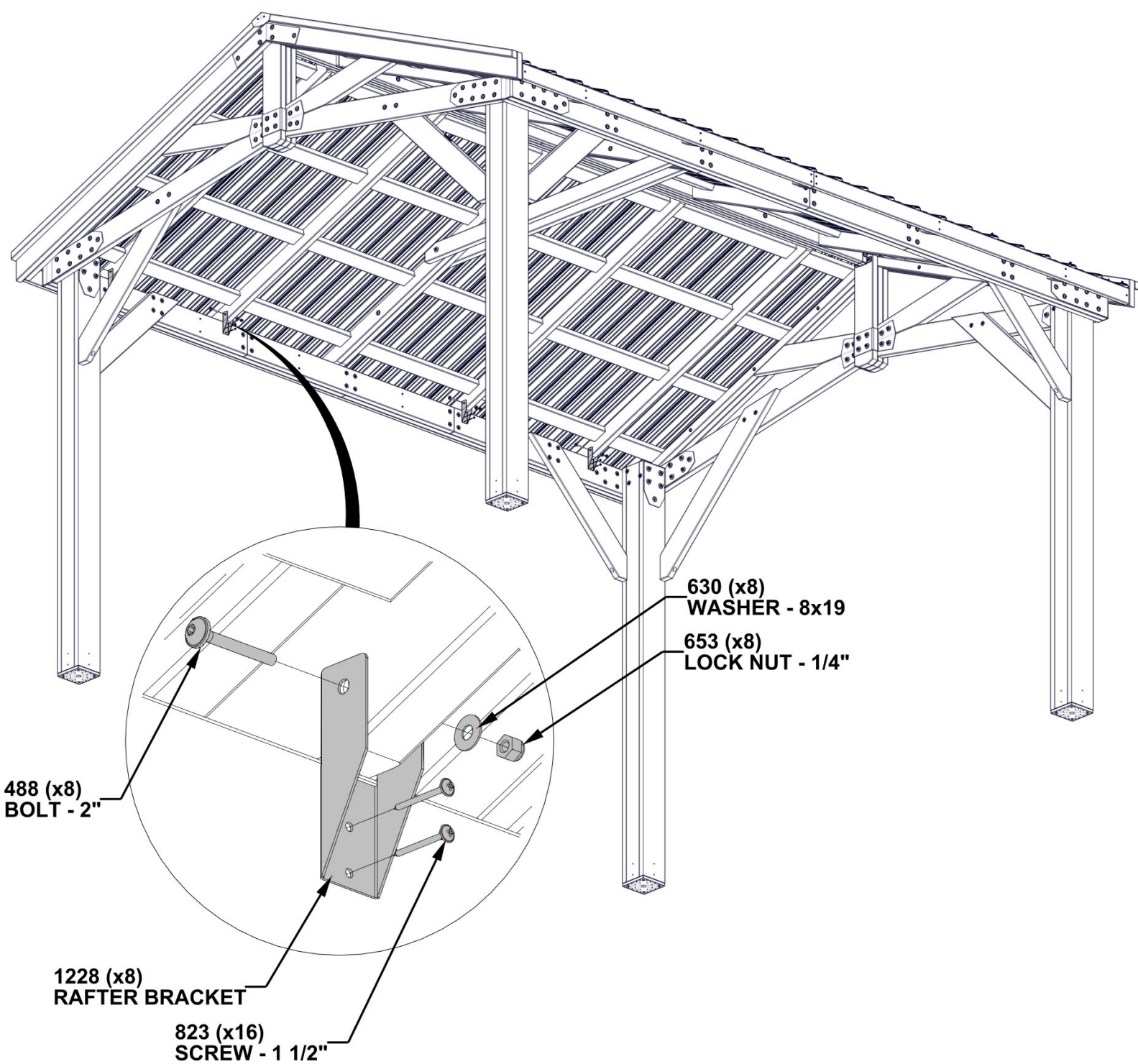

STEP 39 - ROOF ASSEMBLY

QTY	PART NUMBER	DESCRIPTION
20	H100759	SCREW SELF TAPPING 1/4x1

A4M01254 | ROOF EDGE TRIM
(x4)

A4M00983 | ROOF EDGE TRIM SPLICE
(x2)

COMPLETE ON BOTH SIDES.

DUE TO MULTIPLE LAYERS OF METAL ON THE EDGE TRIM, IT IS RECOMMENDED THAT A 1/8" DRILL BIT IS USED TO CREATE STARTER HOLES.

SCREWS GO THROUGH EDGE TRIM INTO THE TOP OF THE RIBS IN THE APPROXIMATE LOCATIONS SHOWN.

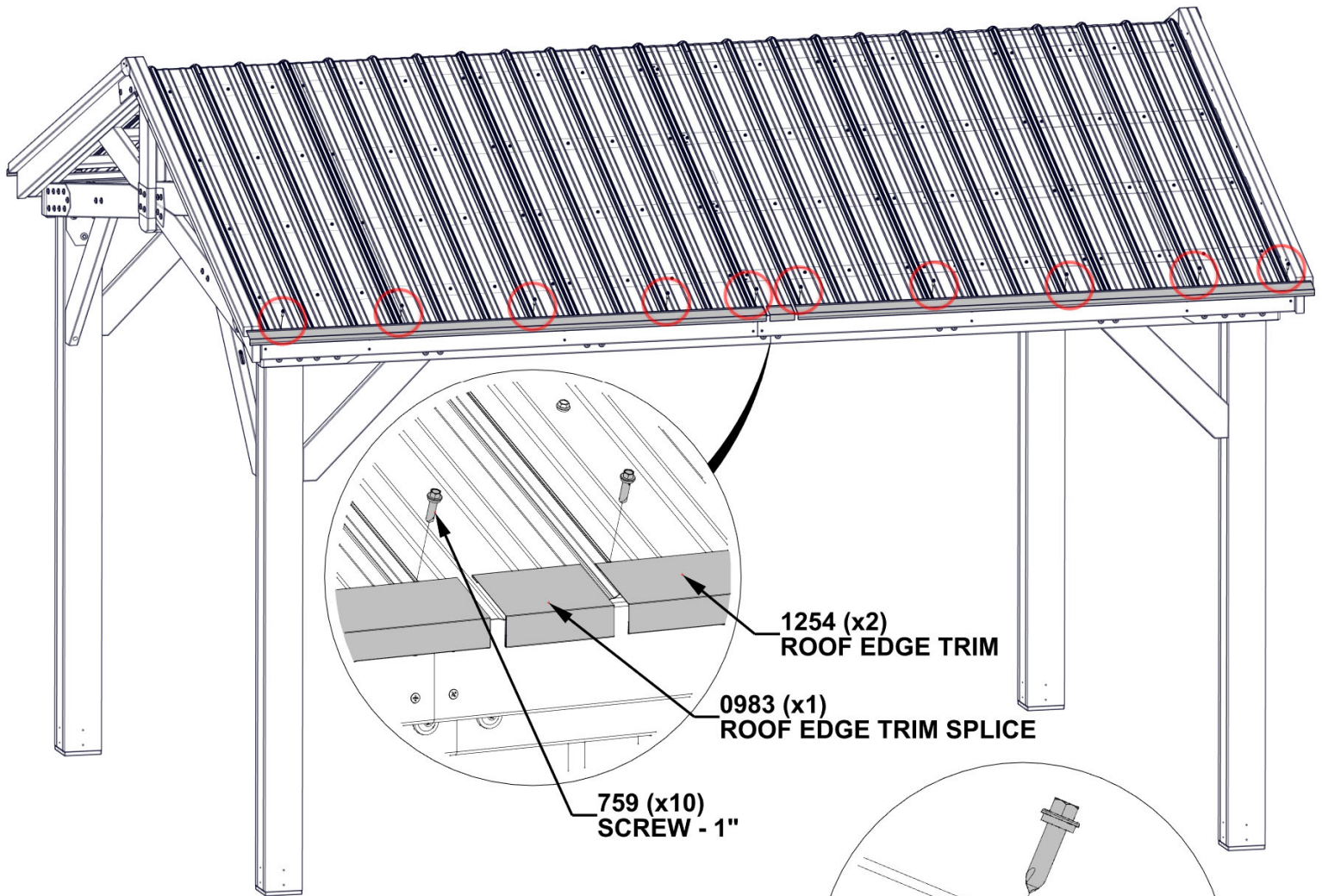

SLIDE TRIM INTO SPLICE ENSURING THAT BOTH ENDS ARE FLUSH WITH THE EDGES OF ROOF PANELS.

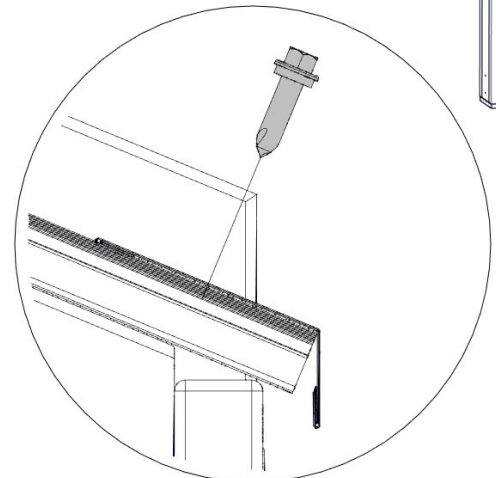

SIDE VIEW

STEP 40 - ROOF ASSEMBLY

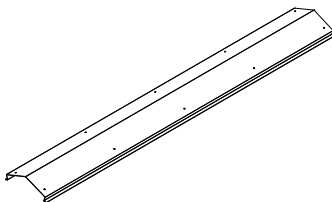

A4M01127 | RIDGE CAP SPLICE
(x1)

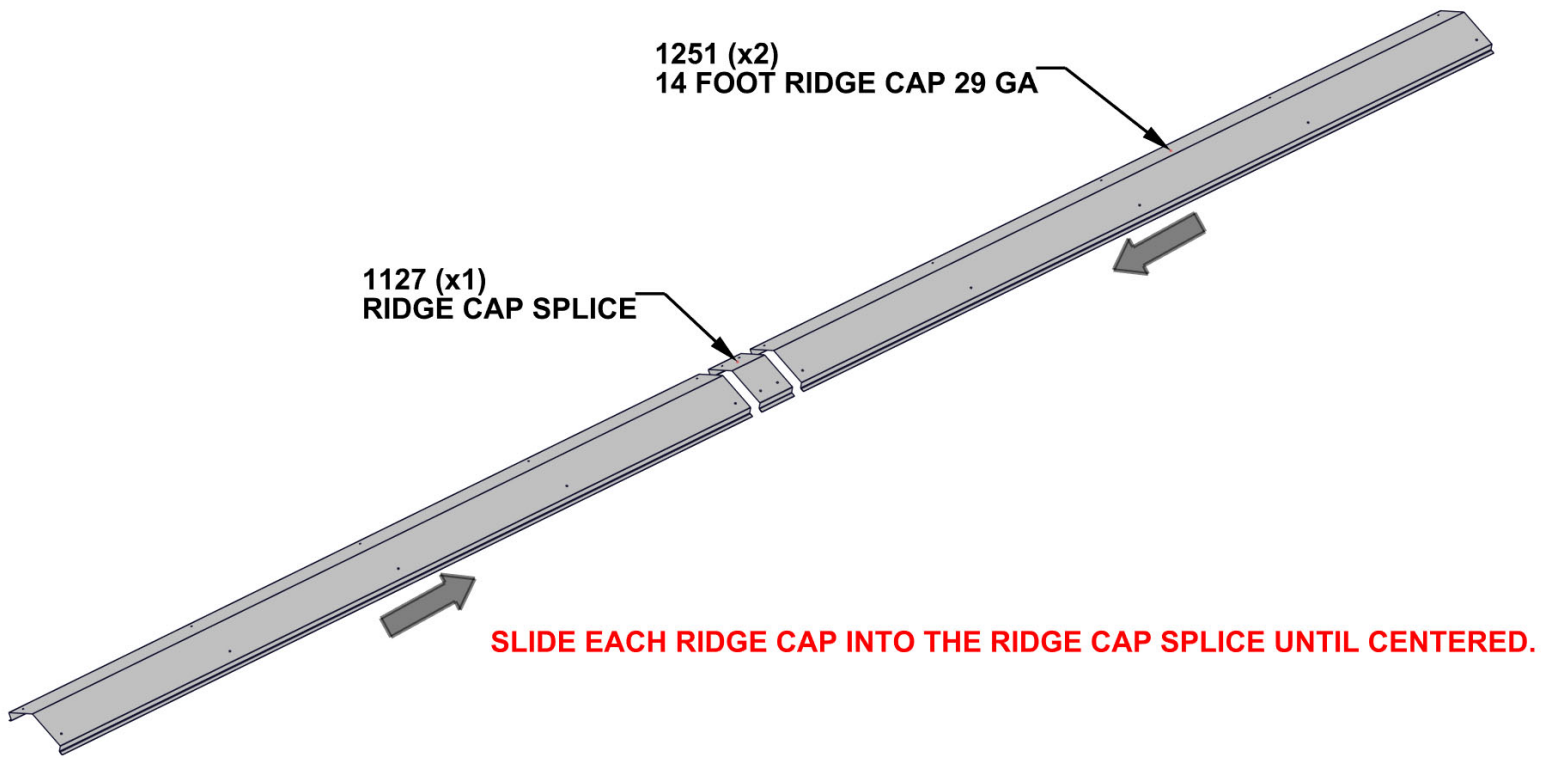
A4M01251 | 14 FOOT RIDGE CAP 29 GA
(x2)

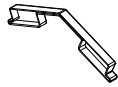

STEP 41 - ROOF ASSEMBLY

QTY	PART NUMBER	DESCRIPTION
20	H100833	SCREW WOODGRIP 10-16x3/4"



A6P00398
(x2) | **RIDGE CAP PROTECTOR**

J09 | **RIDGE CAP STIFFENER - W4L16897**
(x2) | 1"x2 3/8"x77 5/8" (24x60x1973)

J10 | **RIDGE CAP STIFFENER - W4L16898**
(x2) | 1"x2 3/8"x89 1/2" (24x60x2273)

ASSEMBLE BY ALIGNING THE HOLES ON EACH RIDGE CAP TO THE HOLES IN THE RIDGE CAP SPLICE.

FINAL LENGTH - 13'-11 3/8" [4250mm]

REMOVE SPACERS FROM RIDGE CAP PROTECTORS BEFORE INSTALLING.

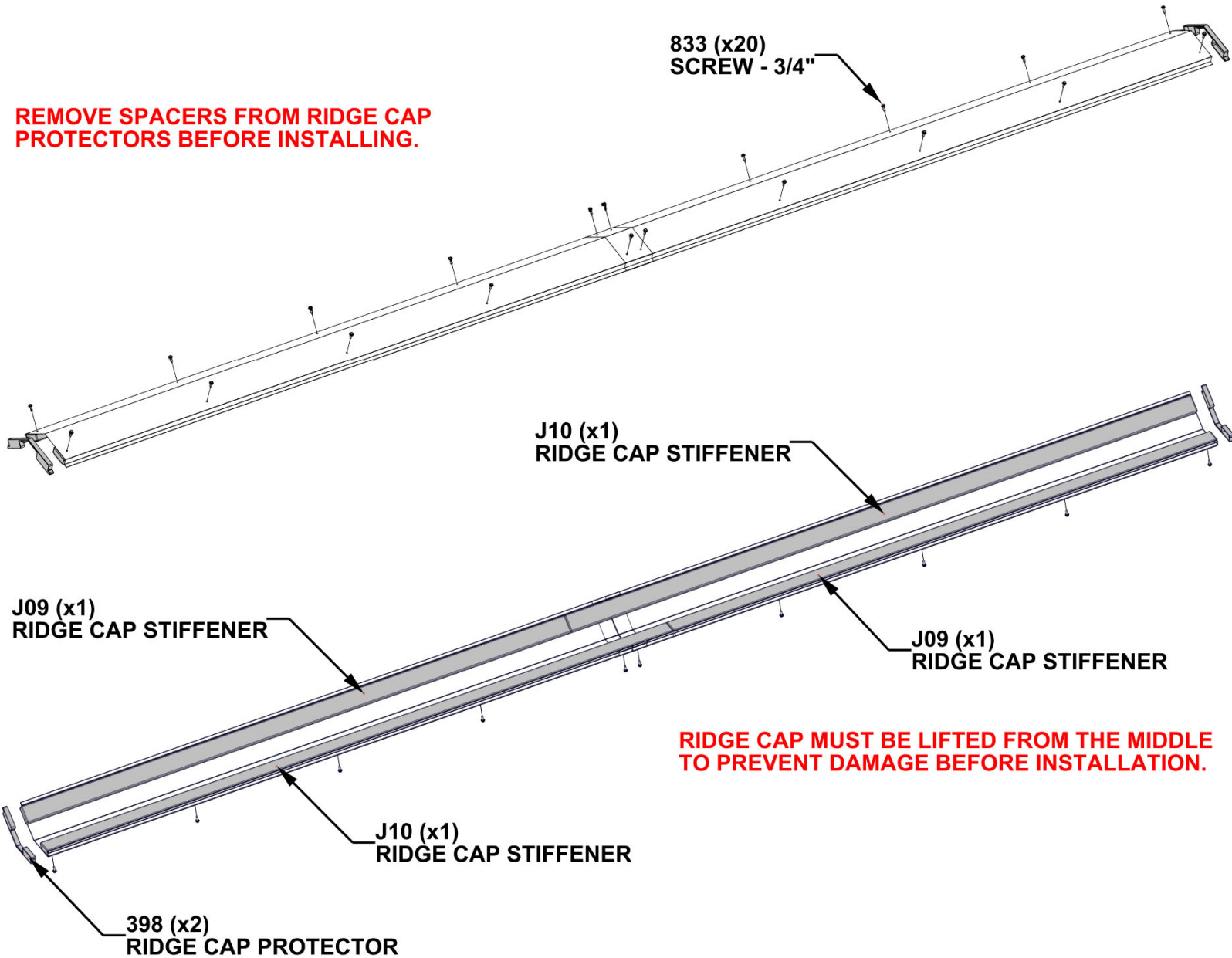

RIDGE CAP MUST BE LIFTED FROM THE MIDDLE TO PREVENT DAMAGE BEFORE INSTALLATION.

STEP 42 - ROOF ASSEMBLY

QTY	PART NUMBER	DESCRIPTION
22	H100392	SCREW PWH 8x3/4 BLK



RIDGE CAP ASSEMBLY - FROM PREVIOUS STEPS

**DO NOT CLIMB ON ROOF TO INSTALL:
ROOF CAP HAS BEEN DESIGNED TO
INSTALL WITH THE USE OF A LADDER.**

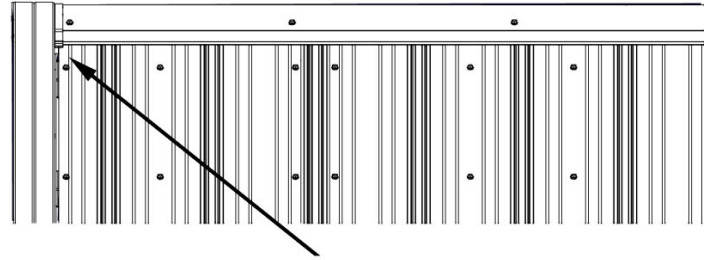
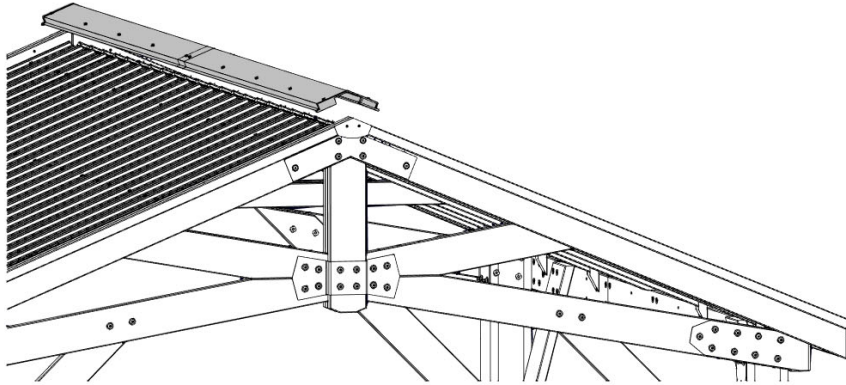

USING AN ADULT HELPER, SLIDE RIDGE CAP ASSEMBLY ACROSS THE ROOF RIDGE UNTIL BOTH ENDS SIT INSIDE RAFTERS AS SHOWN.

FOR PROPER INSTALLATION, USE AN ADULT HELPER TO KEEP DOWNWARD PRESSURE ON THE RIDGE CAP WHILE SCREWING IN SCREWS.

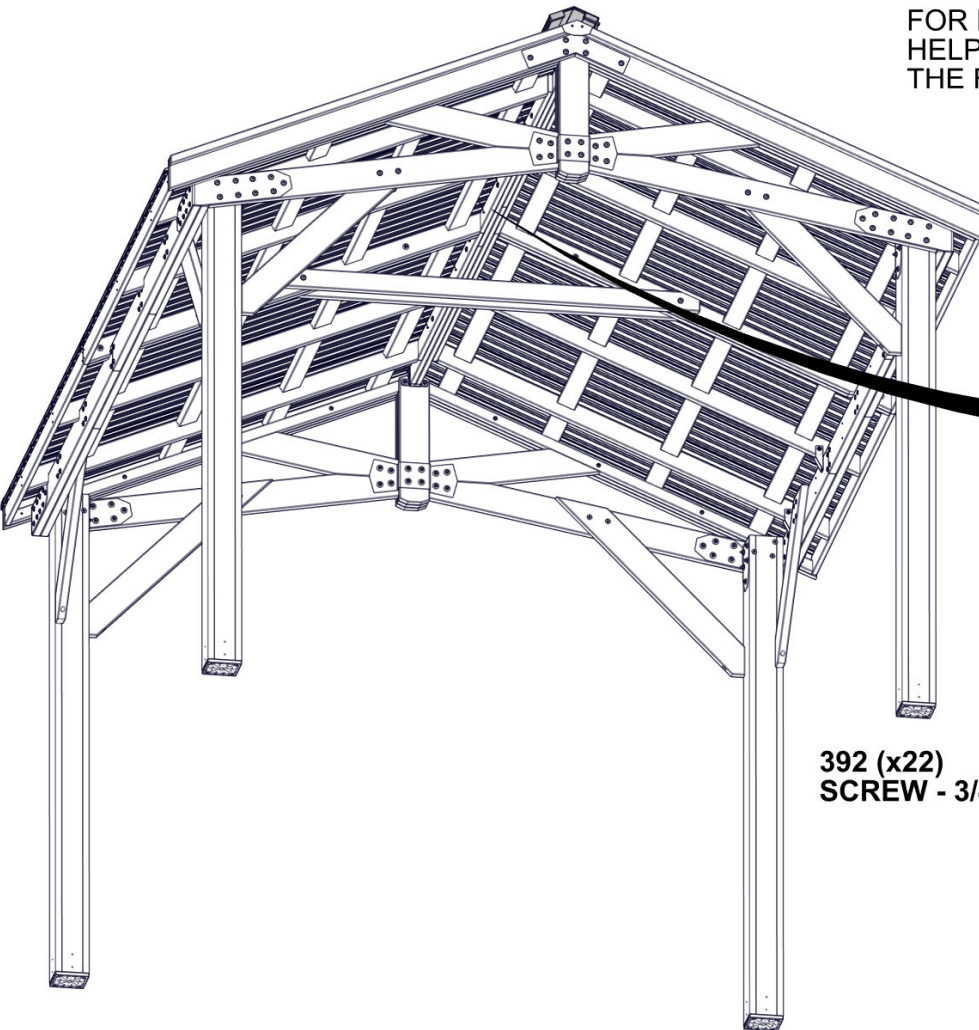

392 (x22)
SCREW - 3/4"

INSTALL SCREWS THROUGH PILOT HOLES IN ROOF PANELS INTO RIDGE CAP STIFFENER BOARDS.

STEP 43 - GAZEBO ASSEMBLY

QTY	PART NUMBER	DESCRIPTION
32	H100471	LAG SCREW WH 5/16x1 1/2 BLK



A4M00978
(x8) | **POST PLATE**

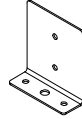

A4M00977
(x8) | **POST ANCHORING PLATE**

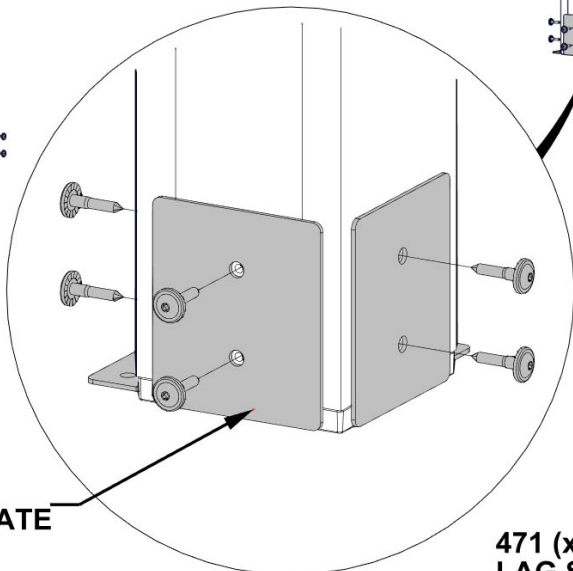
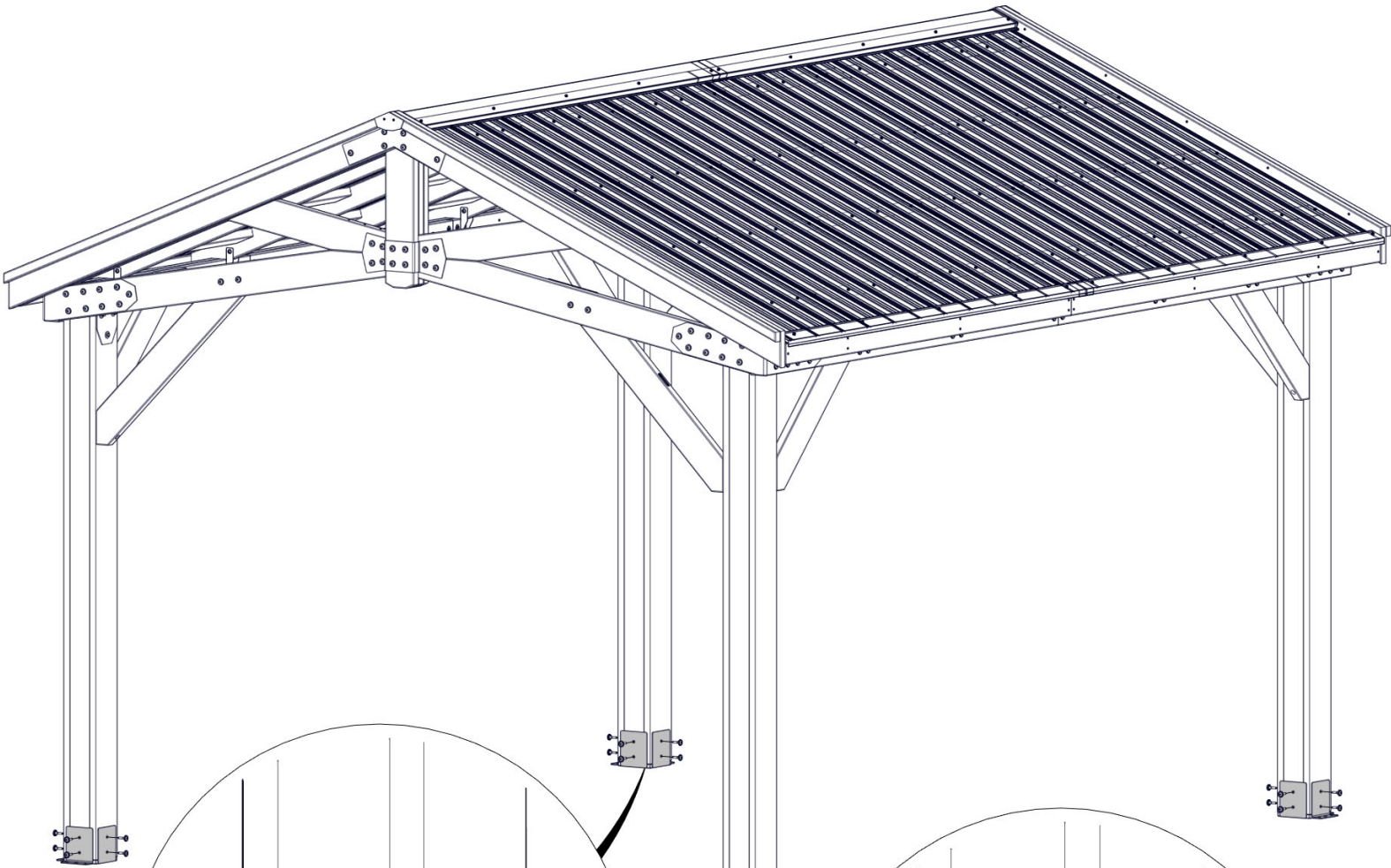

0978 (x8)
POST PLATE

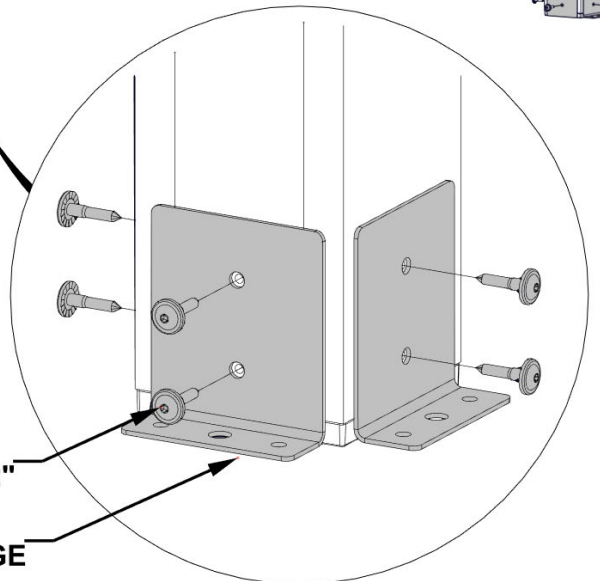

471 (x32)
LAG SCREW - 1 1/2"

0977 (x8)
POST ANCHORING PLATE WITH FLANGE

STEP 44 - GAZEBO ASSEMBLY

QTY	PART NUMBER	DESCRIPTION
2	H100200	SCREW PFH 8x1 1/2 BLK



A100241 BYD ID TAG
(x1) (SMALL)
WITHOUT AGES

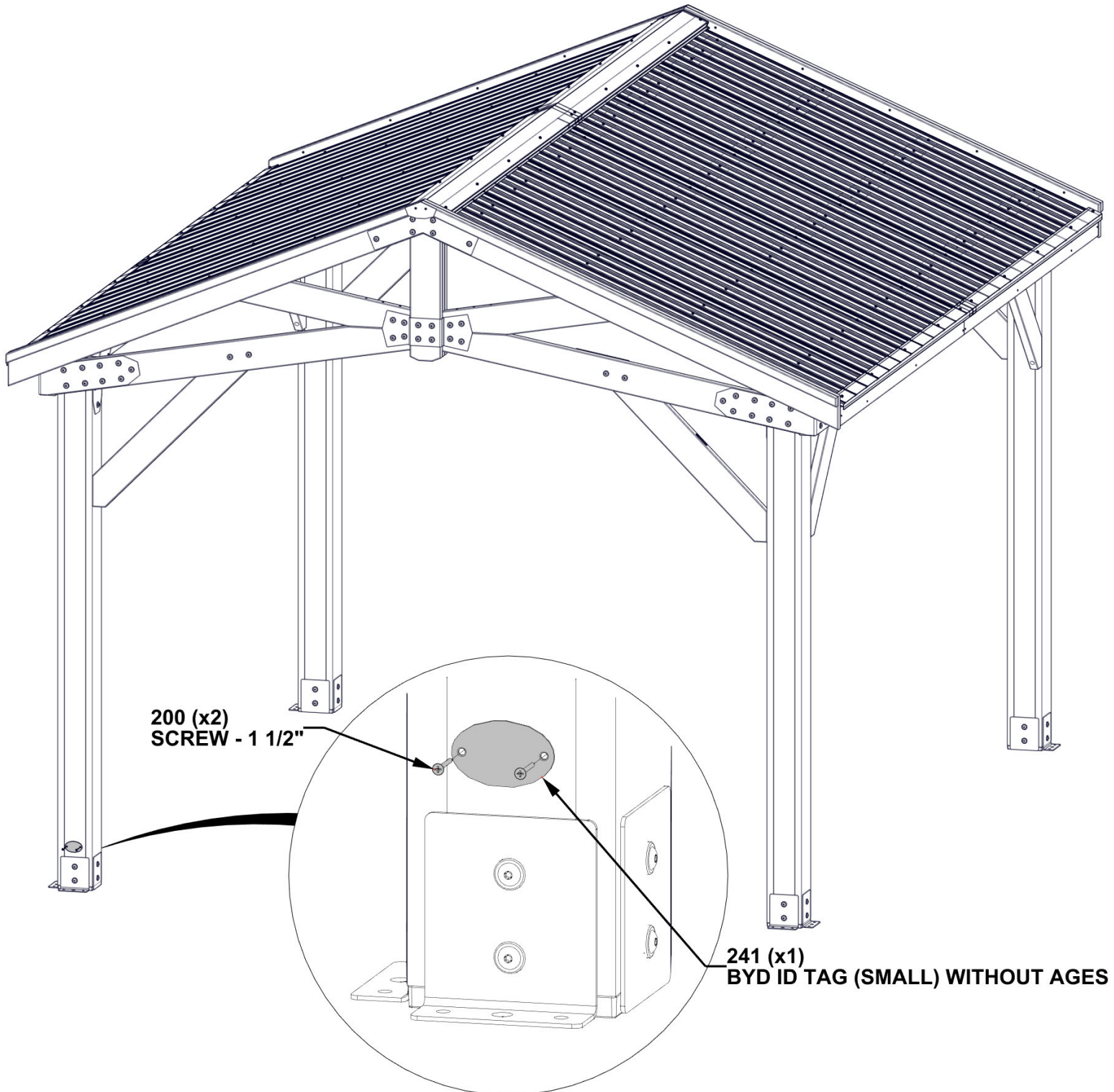

STEP 45 - GAZEBO ASSEMBLY

QTY	PART NUMBER	DESCRIPTION
16	H100120	CONCRETE ANCHOR
16	H100630	WASHER FLAT 8x19 BLK

MANUFACTURER RECOMMENDS INSTALLATION ON CONCRETE SURFACE OR CONCRETE POST PAD AS SHOWN BELOW.

FOR INSTALLATION ON WOOD DECK, YOU MUST ENSURE THERE IS AMPLE STRUCTURAL SUPPORT UNDER THE DECK. HARDWARE NOT INCLUDED FOR DECK ATTACHMENT.

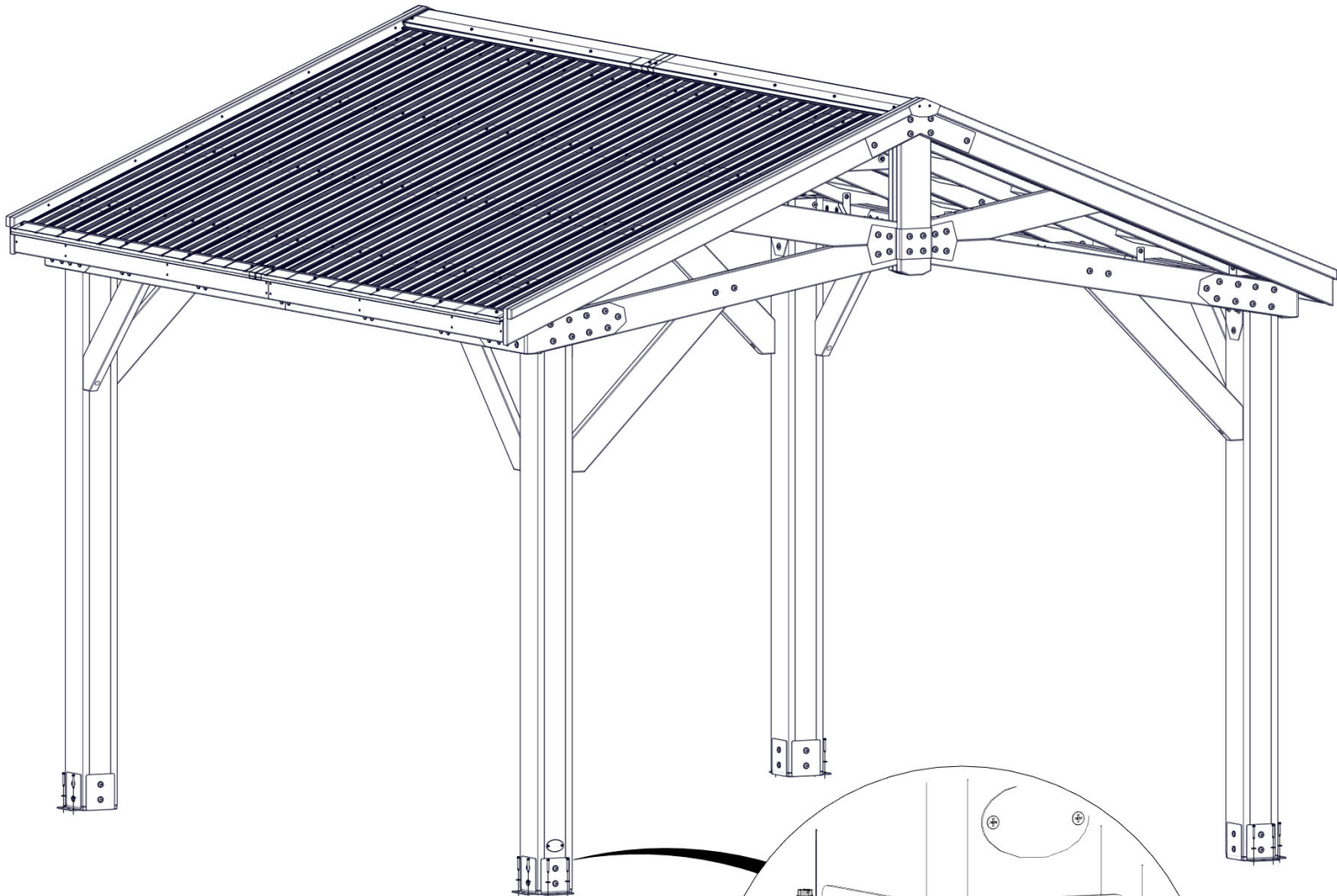

**120 (x16)
SCREW - 2"**

**630 (x16)
WASHER - 8x19**

**PRE-DRILL HOLES FOR CONCRETE ANCHORS
USING A 3/16" CONCRETE DRILL BIT.**

ELECTRICAL ENCLOSURE

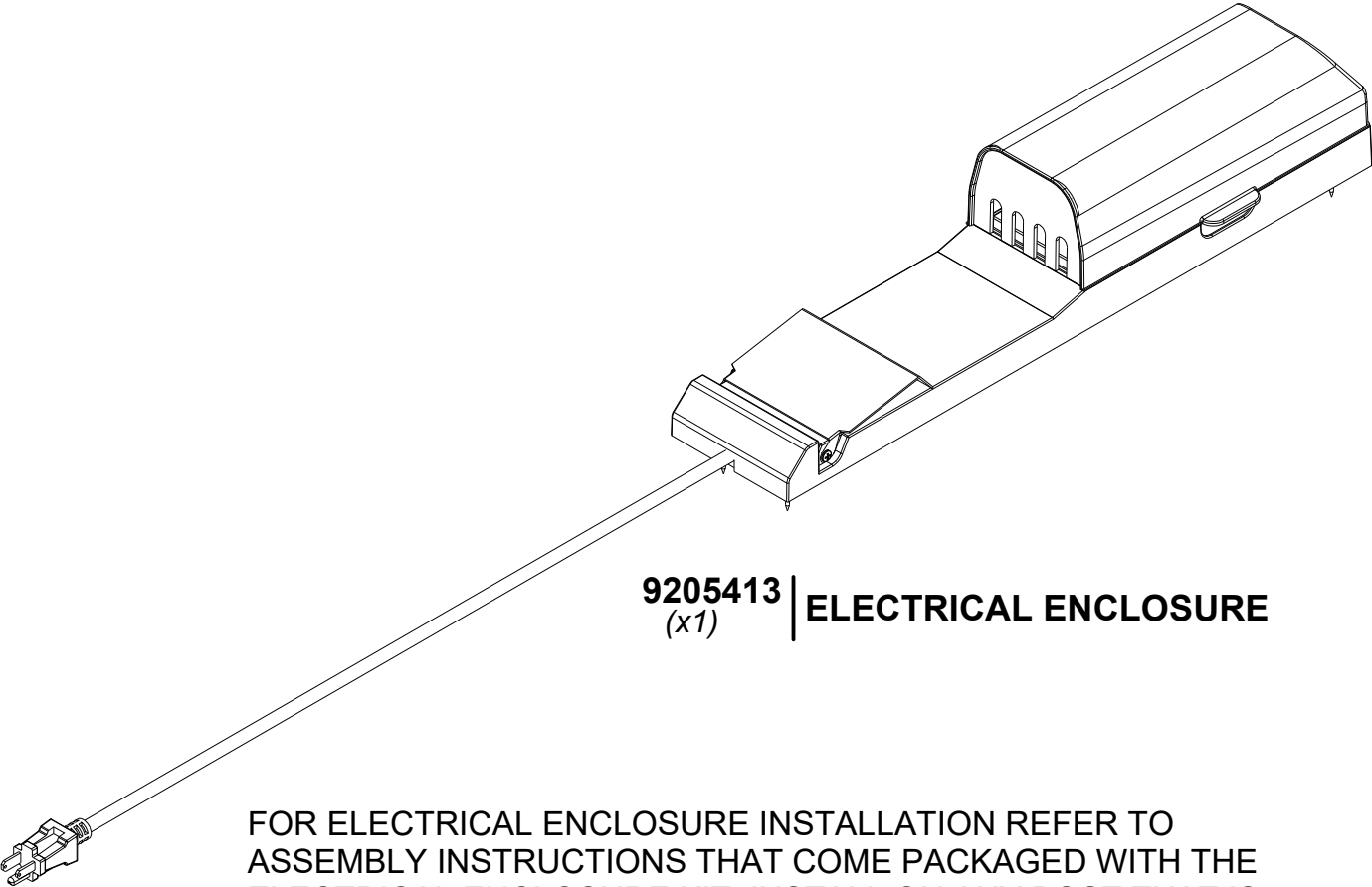

9205413 | **ELECTRICAL ENCLOSURE**
(x1)

FOR ELECTRICAL ENCLOSURE INSTALLATION REFER TO ASSEMBLY INSTRUCTIONS THAT COME PACKAGED WITH THE ELECTRICAL ENCLOSURE KIT. INSTALL ON ANY POST THAT IS DESIRED. FOLLOW DIRECTIONS FOR PROPER INSTALLATION.